

Data I/O has made a conscientious effort to ensure that the information in this document is accurate and complete. Data I/O assumes no liability for errors, or for any incidental, consequential, indirect, or special damages, including, without limitation, loss of use, loss or alteration of data, delays, or lost profits or savings, arising from the use of this document or the product which it accompanies.

No part of this document may be reproduced or transmitted in any form or by any means, electronic or mechanical, for any purpose, without written permission from Data I/O Corporation.

Data I/O is a registered trademark of Data I/O Corporation.

Data I/O Corporation acknowledges the trademarks of other organizations for their respective products or services mentioned in this document.

© September 2006
Data I/O Corporation
All rights reserved

096-0253-005-F



Table of Contents

1 • Introduction

ImageWriter-200 Features	1-1
ImageWriter-300 Features	1-2
Hardware	1-4
Physical Layer (IW-200 and IW-300)	1-4
Data Pump Layer (IW-200 and IW-300)	1-5
Control Layer (IW-300 only)	1-5
ImageWriter Tools	1-6
USB Interface	1-7
Specifications	1-9
Package Contents	1-10
Safety	1-10
Disposal Directions	1-11
Warranty and Disclaimer	1-11
Contact Data I/O	1-13
Additional Information	1-14

2 • Setup

Power to ImageWriter	2-1
Mounting Dimensions	2-1
Self-test on Power Up	2-2
Connection Options Chart	2-3
Connections for Configuring IW Without a Target Board	2-4
Connections for Programming with IW	2-8
Control Interface Connections for Programming with IW-300	2-10
Control Interface: IW-300 to Push Button Without Isolation	2-11
Control Interface: IW-300 to ATE	2-12
Control Interface: Four Interconnected IW-300s to ATE	2-13
Connections for Link Networking IW-300s for Configuration	2-15
Checking Communication	2-17
ImageWriter Tools Communication Check	2-17
HyperTerminal Communication Check	2-17

3 • Computer Interface Language (CIL) for IW-200

CIL Syntax	3-1
Responses to CIL Commands	3-1
Cancel Command	3-2
Errors	3-2
Memory Commands	3-3
Memory Commands Table	3-4
Object Commands	3-5
Object Commands Table	3-7
System Commands	3-8
System Commands Table	3-8
Terminal Mode Commands	3-9
Terminal Mode Commands Table	3-9
CIL Example	3-10

4 • Computer Interface Language (CIL) for IW-300

CIL Syntax	4-1
Responses to CIL Commands	4-1
Cancel Command	4-2
Errors	4-2
Memory Commands	4-3
Memory Commands Table	4-4
Object Commands	4-5
Object Commands Table	4-7
System Commands	4-8
System Commands Table	4-8
Terminal Mode Commands	4-9
Terminal Mode Commands Table	4-9
Flow Commands	4-10
Flow Commands Table	4-10
Flow Example	4-11
Network Commands	4-12
Network Commands Table	4-12
Network Operation	4-12
NPNG Command Response	4-13
Deselecting IW-300s	4-14
Network Command Examples	4-15

5 • IW-200 Errors

IW-200 Numeric Error Codes (Standard Errors)	5-1
Data Pump Error Blink Pattern (High Priority Errors)	5-3

6 • IW-300 Errors

IW-300 Numeric Error Codes (Standard Errors)	6-1
Data Pump Layer Error Blink Pattern (High Priority Errors)	6-5
Control Layer Error Blink Pattern (High Priority Errors)	6-5

7 • ImageWriter Reference

Data Pump Layer	7-1
Physical Layer	7-2
Physical Layer Connector	7-3
Control Layer	7-4
Control Interface Connector	7-5
Network Interface (Hardware)	7-6
IW-300 Start Up	7-7
Checksum Calculations	7-7
Setup Example: SPI Protocol	7-8
Setup Example: Microchip Serial Protocol	7-9
Setup Example: Control Interface to ATE	7-10
Setup Example: Control Interface to Push Buttons	7-11

- **Appendix A: WEEE Symbol**
 - **Appendix B: EC Declaration of Conformity**
 - **Appendix C: Mounting Dimensions**
 - **List of Tables**
 - **List of Figures**
 - **Index**
-

1

Introduction



Figure 1-1—*ImageWriter-200 (Left); ImageWriter-300 (Right)*

ImageWriter is Data I/O's compact, In-System Programming (ISP) solution for programming Flash-based microcontrollers and serial memory devices on a target board during the manufacturing process. **ImageWriter** programs via SPI, I2C, RS-232, JTAG and other serial interfaces and installs within a test fixture or a test station for programming at any point in the manufacturing process. Two models are available: **ImageWriter-200 (IW-200)** and **ImageWriter-300 (IW-300)**. **ImageWriter Tools (IW Tools)** software application allows you to configure and run **ImageWriter**.

NOTE: See *IW Tools Help* for detailed information about the software.

ImageWriter-200 Features

Hardware for **ImageWriter-200** consists of the Data Pump Layer and the Physical Layer. **IW-200** is controlled by Computer Interface Language (CIL) at run time. Commands and data are issued to **IW-200** over a Virtual COM port that emulates a standard RS-232 serial port in the Microsoft® Windows® environment, allowing simple integration with third-party tools. For manual operation of **IW-200** you can use

HyperTerminal (included with Microsoft Windows). For automated operation, you can create a control system which could be implemented in Visual Basic, LabVIEW, C/C++ or any software that can communicate with a standard COM port in the Windows® environment. **IW Tools** can be used to connect to, select, and update your **IW-200**.

ImageWriter-300 Features

As with **IW-200**, device libraries and data files are sent to **IW-300** over a Virtual COM port that emulates a standard RS-232 serial port in the Windows environment. Static Data is stored on the Compact Flash card on the Data Pump Layer. Control of the **IW-300** is accomplished by CIL commands issued over the Virtual COM port, or via the Control Interface, or by a combination of both. **IW-300** hardware consists of the Data Pump Layer, the Physical Layer, and the Control Layer.

IW-300 offers all the functionality of the **IW-200** and is 100% backwards compatible with all **IW-200** CIL commands and software tools. While **IW-200** is controlled by Computer Interface Language (CIL) at run time, **IW-300** can initiate programming processes and provide feedback via the Control Interface. A computer is not required to operate **IW-300** at run time. **IW Tools** is used to configure **IW-300** (download data files, device libraries, Flow files) prior to run time.

An **ImageWriter-300** can be used by itself, or it can be combined with other **ImageWriter-300s** in three ways:

- Link Networked
- USB Networked
- Interconnected

Link Networked

In a *Link Network*, up to 32 **IW-300** modules can be configured simultaneously, with the *master IW-300* connected to the computer via the USB cable and up to 31 *linked IW-300s* connected in line via the Link Input and Link Output connectors on the Control Layer.

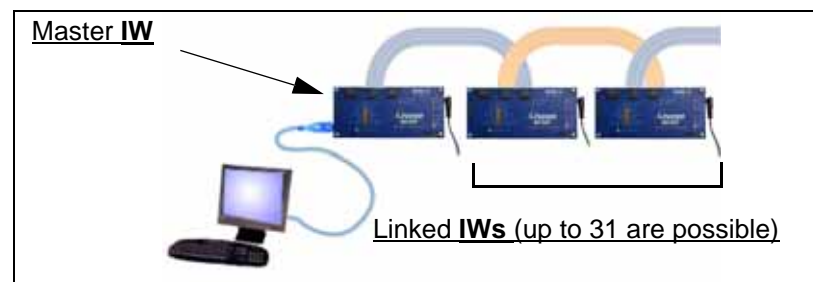

Figure 1-2—Link Networked **IW-300s**

A Link Network provides simplified multi-module data management, serialization (Dynamic Data), and system-control features. You can also manage multiple Link Networks (of up to 32 **IW-300s** in each network) through the use of a USB hub, making the total number of **IW-300** modules in use limited only by the computer's USB capacity.

USB Networked

With a *USB Network* you can configure multiple **IW-300** modules, each connected to the computer via a USB cable. You are limited only by the computer's USB capacity. In a USB Network you can send different device libraries or data files to different **IW-300** modules, or you can send the same device library and data file to all USB Networked **IW-300** modules.

In addition, you can build *USB Networked Link Networks*, where the **IW-300** connected to the computer via USB cable serves as the *master IW-300* for up to 31 *linked IW-300s* connected via the Link Input/Link Output connectors.

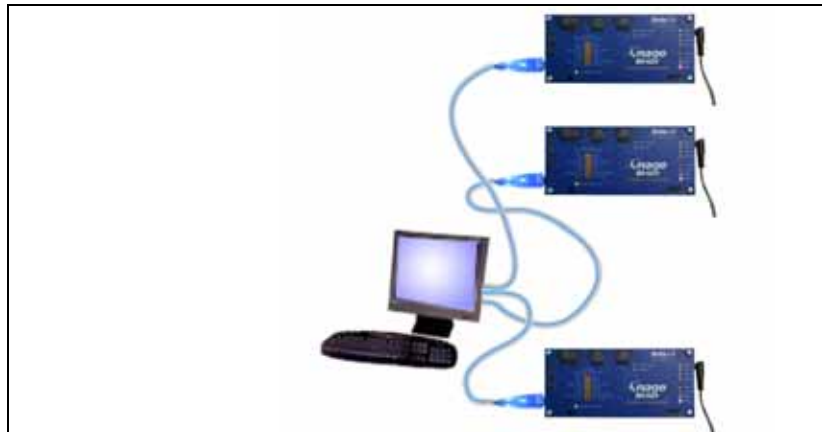

Figure 1-3—USB Networked **IW-300s**

Interconnected

With *Interconnected IW-300s* you can program multiple devices. No computer is required at run time. Interconnected **IW-300s** receive *Start* and *Reset* signals, for example, from an ATE or mechanical contact closure. The connection to **IW-300** Control Interfaces can be shared or grouped by the same signal that is fanned out from the ATE or other equipment connections.

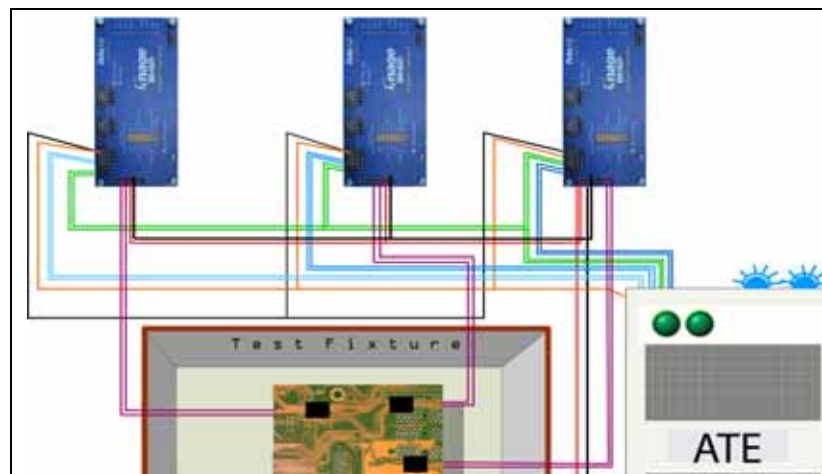

Figure 1-4—Interconnected **IW-300s**

Hardware

IW-200 hardware consists of a Physical Layer (lower layer shown in [Figure 1-5](#)) and a Data Pump Layer (middle layer shown in [Figure 1-5](#)). **IW-300** hardware consists of a Physical Layer, a Data Pump Layer, and a Control Layer (upper layer shown in [Figure 1-5](#)).



Figure 1-5—IW-300 Showing Three Layers of Hardware

Physical Layer (IW-200 and IW-300)

The Physical Layer provides electrical drivers and connection for various protocols, including RS-232, I2C, SPI, and JTAG. Included on the Physical Layer are a round Auxiliary Power Connector (Auxiliary Power Input) for use with an AC Adapter; a power supply which supplies power for the entire IW system; and LEDs that indicate Regulator (D4), Overcurrent (D5), VPP/EXT_ON (D8), and Power to the Physical Layer (D9). For more information on the Physical Layer, see [“Physical Layer” on page 7-2](#).

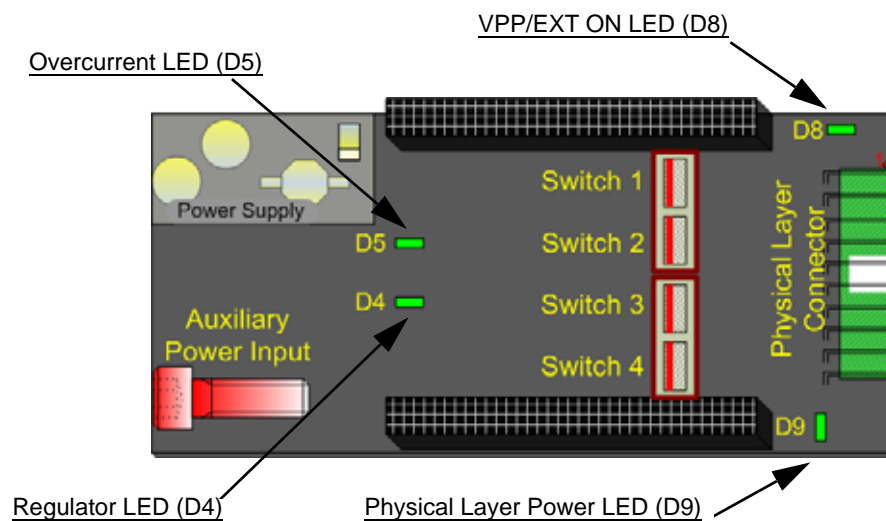

Figure 1-6—Physical Layer

Data Pump Layer (IW-200 and IW-300)

The Data Pump Layer contains all memory, such as the image of the data which you write to the target device. It also contains target device-specific drivers, and a USB interface for control. Power to the Data Pump Layer is provided by the Physical Layer. Three LEDs on the Data Pump provide information about USB data transmission (D1), Status (D2) and Data Pump Power (D3). For more information on the Data Pump, see [“Data Pump Layer” on page 7-1](#).

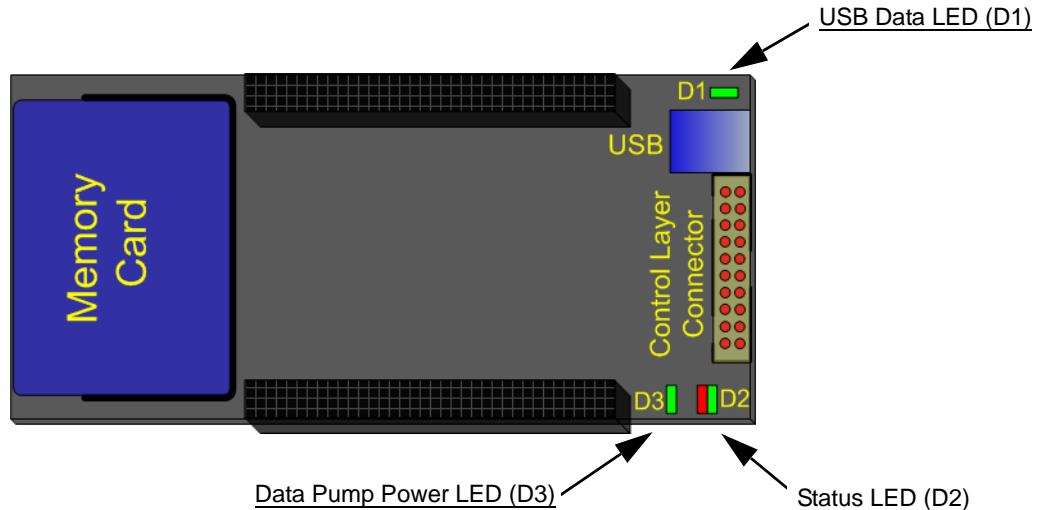

Figure 1-7—Data Pump Layer



CAUTION: After a Memory Card is put into *ImageWriter*, the card is no longer usable by a computer or other consumer devices.

Control Layer (IW-300 only)

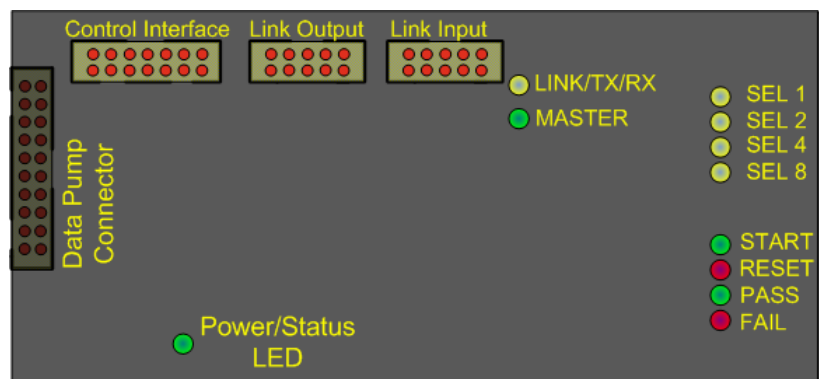

Figure 1-8—Control Layer

The Control Layer provides an isolated Control Interface connector for selecting and running up to 16 pre-made jobs or "Flows" without

the assistance of a computer; two connectors for Link Networking **IW-300s** (Link Output and Link Input); and eight LEDs to monitor the status of the Control Interface (SEL 1, SEL 2, SEL 4, SEL 8, START, RESET, PASS, FAIL). The LINK/TX/RX (link, transfer, receive) LED and the MASTER LED monitor Link Network activity. A global Power/Status LED indicates overall **IW-300** status. Power to the Control Layer is provided by the Physical Layer. For more information on the Control Layer, see “[Control Layer](#)” on page 7-4.

ImageWriter Tools

Your **ImageWriter** came with **ImageWriter Tools (IW Tools)**, a software application that includes Programmer Control Panel and Flow Editor features.

IW Tools main interface looks like this:

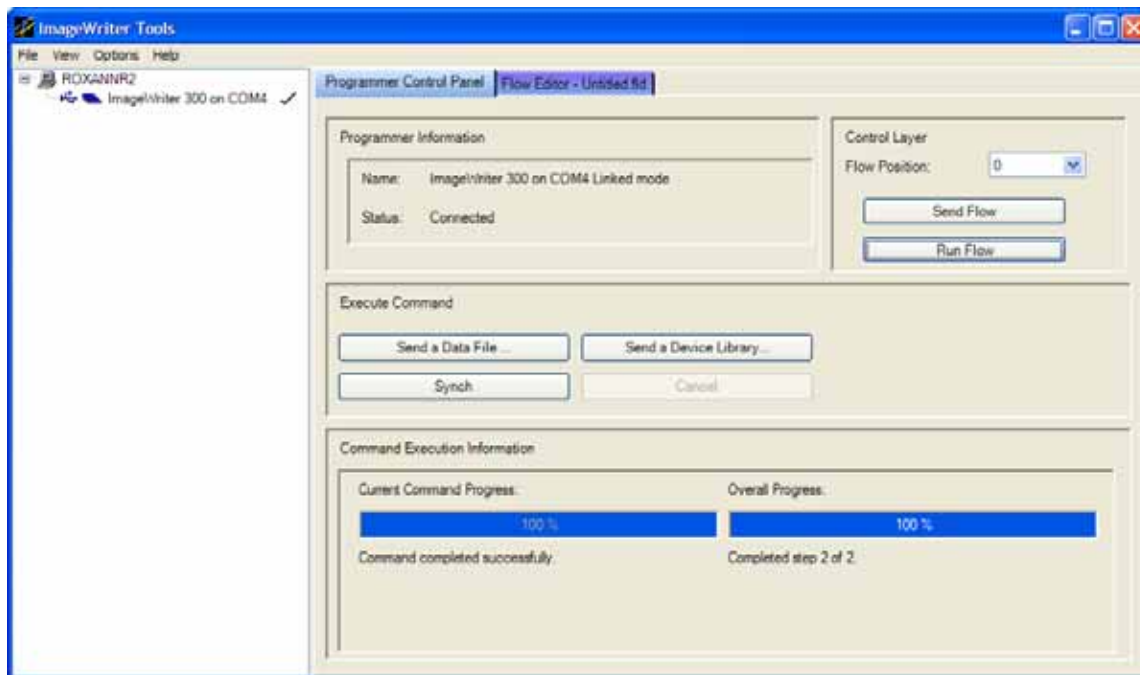

Figure 1-9—**ImageWriter Tools**

With Programmer Control Panel you can:

- Select and connect to your **ImageWriters**
- Download device libraries, data files, and Flows to your **ImageWriters**
- Update the Control Layer firmware on your **ImageWriters**

With Flow Editor you can:

- Create or edit a Flow, a sequence of steps to accomplish a programming process

For more information about **IW Tools**, see **IW Tools Help**. To open **IW Tools Help**, select **Help > Contents**:

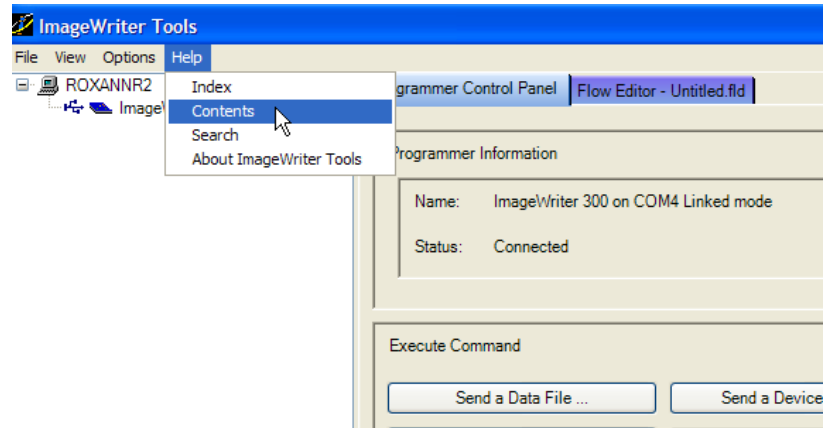

Figure 1-10—Open **IW Tools Help**

IW Tools Help opens:

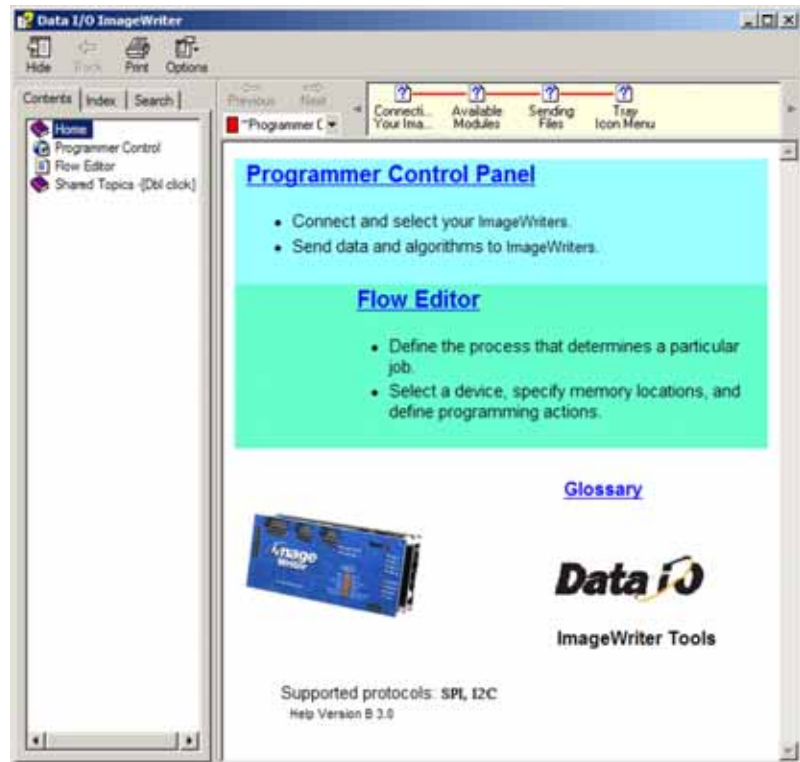

Figure 1-11—**ImageWriter Tools Help**

USB Interface

When **ImageWriter** is connected to a computer via the USB cable, a supported Windows® operating system automatically detects a new Plug and Play device, and a message is displayed in the System tray indicating a new device has been detected.

The first time a new **ImageWriter** is connected to a computer running Windows XP or Windows 2000 Operating System, **ImageWriter** is assigned to a COM port (for example, COM 6). Regardless of how many times you unplug and move this **ImageWriter**, it will always be COM 6 on this computer. However, if you plug this **ImageWriter** into a different computer, it is assigned a COM port number unique to that computer. The new COM port may be different from the COM port number assigned by the first computer.

NOTE: When **ImageWriter** is unplugged or power is removed, Windows® removes the Virtual COM port until **ImageWriter** is plugged back in or power is restored.

Specifications

Physical / Environmental	
Operating Voltage	9-24 VDC
Physical Measurement	IW-200: 127 mm x 58 mm x 20 mm (5" W x 2.3" D x 0.79" H) IW-300: 127 mm x 58 mm x 33 mm (5" W x 2.3" D x 1.3" H)
Operating Temperature Range	13° to 35° Centigrade (55° to 95° Fahrenheit)
Operating Humidity (non-condensing)	0% to 70%

Facilities	
DC Input Voltage Requirements	9-24 VDC
DC Input Power (max)	5 Watts
Pin Driver Output Capabilities	Down to 1.5V
Max In on Target V+	8V
Max In on Pod Power	24V
Max Digital Inputs Max Voltage	5.1V
Max Voltage Input on I2C Bus	5.5V
Max Input on RS-232 Inputs (non-digital mode)	24V
Max Input on VPP/Ext Voltage	24V, 1A

ImageWriter Operating Features	
Computer Interface	USB 2.0 compliant
Regulatory Compliance	EC

Computer Requirements	
Operating System	Windows® 2000 / XP
Facilities	USB Port

Table 1-1—*ImageWriter Specifications*

Package Contents



Figure 1-12—Package Contents

Safety

ImageWriter is a low voltage device. When operating **ImageWriter**, use “inherently safe technologies, processes, and power supplies” per standard *EN 292, Safety of machines; basic concepts, general principles for design*.

The printed circuit boards in **ImageWriter** are susceptible to electrostatic discharge (ESD) which can damage the circuitry. Use ESD handling precautions (EN 61340-5-1 and CEI/IEC 61340-5-1) when handling and installing. When not in an ESD Protected Area, it is best to handle **ImageWriters** in low charging (antistatic) bags.



Symbol	Description
	Electrical Hazard
	Electrostatic Discharge
	General Caution

Figure 1-13—Warning Symbols Used in This Guide

Disposal Directions



CAUTION: Do not dispose of **ImageWriter** in a standard disposal container.

Dispose of **ImageWriter** in a separately managed collection for electronic equipment (per Directive 2002/96/EC), or return **ImageWriter** to Data I/O at no charge. For contact information on your nearest Data I/O office, see [“Contact Data I/O” on page 1-13](#).



Figure 1-14—“Do Not Dispose” Label

Warranty and Disclaimer

Typical implementation of **ImageWriter** includes but is not limited to external power provision to **ImageWriter**, device access restrictions on the target board, external hardware on the target board, or software changes created by the user affecting timing, device erasure, programming, or verification. Data I/O warranty coverage applies only when the product is used in conformance with technical specifications put forth by Data I/O and by the semiconductor device manufacturer.

To achieve the highest levels of safety and quality, Data I/O recommends that all programming processes be tested and documented in a prototype project prior to transition to volume manufacturing.

ImageWriter programs semiconductor devices through the use of circuits designed precisely to operate in accordance with specifications outlined by the device manufacturer. Provision and calibration of power supplies are critical for proper operation. **ImageWriter** has been fully tested by Data I/O Corporation for quality performance.

Data I/O Corporation warrants this product against defects in materials and workmanship at the time of delivery and thereafter for a period of one (1) year. The foregoing warranty and the manufacturers' warranties, if any, are in lieu of all other warranties, expressed, implied, or arising under law, including, but not limited to, the implied warranties of merchantability and fitness for a particular purpose. For warranty matters, contact Data I/O Customer Support at the numbers listed in [“Contact Data I/O” on page 1-13](#).

If your address has changed, please notify Data I/O Customer Support. This ensures that you receive information about **ImageWriter** enhancements. Be sure to include the serial number located on the bottom of **ImageWriter**.

Contact Data I/O

Worldwide	
Address	Data I/O Corporation
	6464 185th Avenue N.E., Suite 101
	Redmond, WA USA 98052
Telephone	425-881-6444
USA only Toll-free	1-800-3 DATAIO (1-800-332-8246) and press 2
Fax	425-869-7423
E-mail	support@dataio.com
China	
Address	Data I/O China
	Suite A, 25F Majesty Building
	138 Pudong Avenue
	Shanghai, China PRC 200120
Telephone	21-5882-7686
Fax	21-5882-5053
Hong Kong	
Address	Data I/O Hong Kong
	Unit B, 12/F, Aubin House
	171-172 Gloucester Road
	Wanchai, Hong Kong
Telephone	852-2558-1533
Fax	852-2558-1035
Germany	
Address	Data I/O GmbH
	Lochamer Schlag 5
	82166 Gräfelfing, Germany
Telephone	89-85858-66
Fax	89-85858-10
E-mail	ccs-europe@data-io.de

Table 1-2—Contact Information

Other Countries

For customer support in other countries, contact your local Data I/O representative. To find your local representative, go to www.dataio.com/contact/repsearch.asp.

Additional Information

You can find answers to your questions about **ImageWriter** and In-System Programming by visiting our Knowledge Base on our Web site at <http://www.dataio.com>. Click **Support**, and then click **Knowledge Base Search**.

See “In-System Programming Design Guidelines” at <http://www.dataio.com/isp> for design information.

2

Setup

Setup for **ImageWriter** involves making physical connections. The connections vary depending on what you want to do — download a device library to **ImageWriter**, link together multiple **IW-300s**, or program a target device using **ImageWriter**. The chart on [page 2-3](#) lists various goals and refers you to the heading in this chapter that describes the physical connections on **ImageWriter** to accomplish your goal.

Power to ImageWriter

You can supply power to **ImageWriter** two ways:

- **Use the Auxiliary Power Connector** by plugging an AC Adapter into the round Auxiliary Power Connector on **IW's** Physical Layer. This is a convenient way to provide power to **IW** when not wired into a target environment (for example, when **IW** is used at an engineer's desk). Data I/O recommends using the Auxiliary Power Connector when configuring **IW**, i.e., downloading a device library or data file (**IW-200 & IW-300**), or creating a Flow (**IW-300** only).
- **Use Pins 19 and 20** on the Physical Layer Connector by wiring power to these two pins as shown in the **PHYSICAL LAYER CONNECTOR SETUP CHART** for your selected device. This is the recommended way to supply power to **IW** when placed in a test fixture.

This chapter contains information on both methods of supplying power to **ImageWriter**.

Mounting Dimensions

See “[Appendix C: ImageWriter Mounting Dimensions and Template](#)” for information about mounting **ImageWriter** in a test fixture or other installation.

Self-test on Power Up

When you connect power to **ImageWriter**, the Power/Status LED lights up, and the Self-test runs for approximately 10 seconds.

During the Self-test:

- **(IW-200 & IW-300)** the Status LED (D2) on the Data Pump cycles color from red to yellow to green.
- **(IW-300)** the row of LEDs on the Control Layer blinks sequentially.

If the Self-test PASSES:

- **(IW-200 & IW-300)** the Status LED (D2) on the Data Pump Layer stops cycling colors.
- **(IW-300)** the row of LEDs on the Control Layer stops blinking.

If the Self-test FAILS:

- **(IW-200 & IW-300)** the Status LED (D2) on the Data Pump Layer emits a pattern of blinks with a pause of 1.5 seconds between cycles of the blink pattern. For information about the blink patterns, see [“Data Pump Error Blink Pattern \(High Priority Errors\)” on page 5-3 \(IW-200\)](#) or [page 6-5 \(IW-300\)](#).
- **(IW-300)** the Fail LED blinks. For information about the blink patterns, see [“Control Layer Error Blink Pattern \(High Priority Errors\)” on page 6-5](#).

Connection Options Chart



CAUTION: *ImageWriter* is susceptible to electrostatic discharge (ESD) which can damage circuitry. Use ESD handling precautions (EN 61340-5-1 and CEI/IEC 61340-5-1) when handling and installing. When not in an ESD Protected Area, it is best to handle *ImageWriter* in low charging (antistatic) bags.

Select your goal to find the heading for specific setup instructions:

I want to (goal):	Model:	► When:	See heading:
● Download a device library or data file to new IW(s)	IW-200 IW-300	► First time set up	“Connections for Configuring IW Without a Target Board” on page 2-4
● Download a device library or data file to already configured IW(s)	IW-200 IW-300	► Preparing IW to program a different device	
● Program a target device	IW-200	► After downloading a device library with ImageWriter Tools	“Connections for Programming with IW” on page 2-8
	IW-300	► After downloading a device library and/or Flow with ImageWriter Tools	
● Control IW-300 programming operations using external signals	IW-300	► After setting up to program a target device and downloading a device library and/or Flow with ImageWriter Tools	“Control Interface Connections for Programming with IW-300” on page 2-10
● Simultaneously download a device library or data file to more than one IW-300	IW-300	► All IW-300s need to be configured identically	“Connections for Link Networking IW-300s for Configuration” on page 2-15

Table 2-1—Connection Options Chart

The next four headings provide connection procedures for accomplishing different goals with **ImageWriter**.

Connections for Configuring IW Without a Target Board

To download a device library or data file to a new or already configured **ImageWriter-200** or **ImageWriter-300**, complete this procedure.

NOTE: When configuring your **IW**, for convenience you may supply power by plugging an AC Adapter into the round Auxiliary Power Connector on the Physical Layer. The Auxiliary Power Connector is not intended for use when **IW** is installed in a test fixture. When **IW** is installed in a test fixture, Data I/O recommends that you supply power using Pins 19 and 20 on the Physical Layer Connector. See **“Physical Layer Connector”** on page 7-3.

For this procedure you need the USB cable and an AC Adapter.

1. **If you have not already done so, install IW Tools on the computer.**
Insert the **ImageWriter** CD in your computer's CD drive and follow the Setup Wizard.
2. **Plug the USB cable (supplied) into the USB connector on the Data Pump Layer.**



Figure 2-1—Plug the USB Cable into **IW**

3. **Plug the other end of the USB connector into your computer.**
4. **Plug an AC Adapter into the round Auxiliary Power Connector on the Physical Layer (lowest layer).**



Figure 2-2—Plug AC Adapter into Auxiliary Power Connector



WARNING: If your ImageWriter is connected to a power source with a floating ground system (that is, if the ImageWriter ground is different from the computer ground), there is a possible electrical shock hazard to you and danger of damaging the equipment.

In that case you may want to isolate the computer from ImageWriter. USB Opto-Isolators are available from specialty electronics businesses that support optic isolators, data networks, line protection, or ground loop protection. Plug the other end of the AC Adapter into a standard power outlet.

If **ImageWriter** has been previously connected to this computer, a supported Windows® Operating System automatically detects the hardware. Proceed to **Step 5 on page 2-6**.

If this is the first time **ImageWriter** is connected to this computer, the System tray displays the Found New Hardware message:



Figure 2-3— Found New Hardware

The “Found New Hardware” Wizard begins.



Figure 2-4—Found New Hardware Wizard

Complete the “Found New Hardware” Wizard:

- **If you have Internet access for this computer** (recommended), at the prompt “Can Windows connect to Windows Update to search for software?” select “Yes, this time only.” Proceed through the installation Wizard until you have installed the **two required** USB communication drivers.
- **If you do not have Internet access for this computer**, at the prompt “Can Windows connect to Windows Update to search for software?” select “No, not this time.” When directed, insert the **ImageWriter** CD and proceed through the installation Wizard until the **two required** USB communication drivers have been found on your CD-ROM drive *by the Wizard* and installed.

5. **Start IW Tools. Select the COM port where this IW is connected. Click SYNCH.**

NOTE: If the Synch button is not available, click **VIEW > REFRESH PROGRAMMERS**.

6. **Verify the synch was successful.**

Check that the “Command completed successfully” message is displayed in the status bar (see [Figure 2-5](#)), and the Power/Status LED on **ImageWriter** blinks.

7. **Click SEND A DEVICE LIBRARY.**

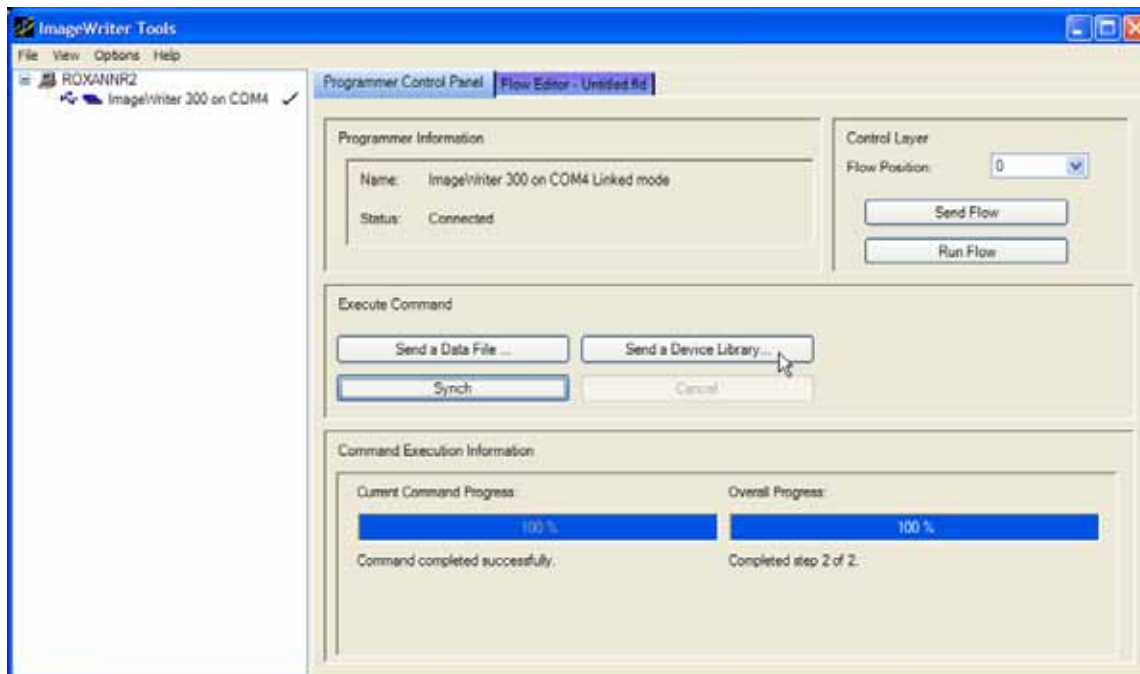

Figure 2-5—After “Command completed successfully”, click **SEND A DEVICE LIBRARY**

8. Select a device library and click SEND.

Figure 2-6—Select Device Library and Click SEND

You can continue to configure **ImageWriter** by:

- Creating a Flow (see **IW Tools** Help topic **FLOW EDITOR > CREATING A FLOW**)
- Sending a data file to **ImageWriter** (see **IW Tools** Help topic **PROGRAMMER CONTROL > SENDING FILES > DATA FILES**)

To use **ImageWriter** to program device(s), continue to **“Connections for Programming with IW”** on the next page.

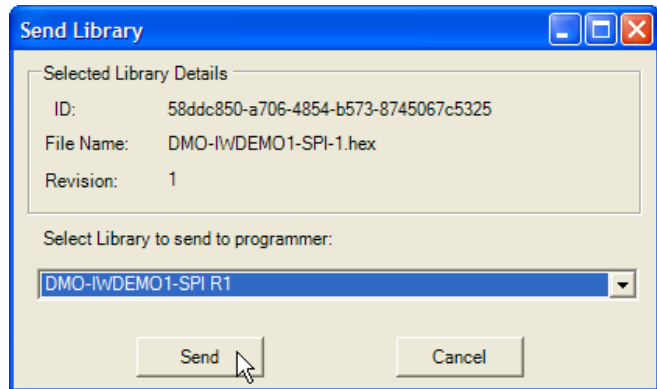
Connections for Programming with IW

To program a target device, complete this procedure. For this procedure you need:

- to know your target device
- *Device Support Detail & Setup* document for your target device (installed at C:\Program Files\Data IO\ImageWriter\Doc)
- one 20-pin, female connector (2-row, 0.1 inch centered, shrouded, and keyed)
- ribbon cable (supplied in IW Accessory Kit) or wire
- hardware to interface to the target board (such as a bed of nails or connector)
- miscellaneous other hardware and equipment to support your particular goals (such as LEDs, switches, DIP switch, connectors, power supply, test fixture, or Automatic Test Equipment)
- and, if you want to use external signals to control **IW-300**, one 14-pin, female connector (supplied in IW Accessory Kit) for each **IW-300**

NOTE: Sample diagrams for Control Interface setup can be found on page 2-11, page 2-12, and page 2-13.

1. Locate the target Device Support Detail & Setup document for your device (installed from the IW Tools / Device Support CD at C:\Program Files\Data IO\ImageWriter\Doc).
2. Scan the document until you find the PHYSICAL LAYER CONNECTOR SETUP CHART. Figure 2-7 shows a sample PHYSICAL LAYER CONNECTOR SETUP CHART.

Physical Layer Connector Setup for ATMEGA128

ImageWriter:		Target:
Connector Pin #	Pin Name	Connections
1	GND	GND
2	GND	GND
3	TXD (MOSI/TDO)	MOSI
4	RXD (MISO/TDI)	MISO
5	RTS (TMS)	NOCONN
6	CTS	NOCONN
7	XCLK	SCK
8	RST	RESET
9	SCL	NOCONN
10	SDA	NOCONN
11	GND	GND
12	GND	GND
13	VPP/EXT_IN	NOCONN
14	VPP/EXT_OUT	NOCONN
15*	Target V+ (noV _{max})	Supply 2.7-5.5 V
16*	Target V+ (noV _{max})	Supply 2.7-5.5 V
17	GND	GND
18	GND	GND
19	ImageWriter Power	Supply 9-24 VDC
20	ImageWriter Power	Supply 9-24 VDC

*Maximum PinDriver output voltage = 4.2V.
 *ATMEGA128L is supported by same menu selection. VDD(Target) = range for ATMEGA128L is 2.7-5.5V, while ATMEGA128 is 4.5-5.5V. All other parameters are identical. See Manufacturer device datasheet for more information.

SAMPLE ONLY

Figure 2-7—Sample **SETUP CHART** in Device Support Detail & Setup Document

3. Wire ImageWriter's 20-pin Physical Layer Connector to your target board according to the PHYSICAL LAYER CONNECTOR SETUP CHART for your target device. You will need to know how your target board is designed and where to make the appropriate connections.

NOTE: All pins specified as connected in the **PHYSICAL LAYER CONNECTOR SETUP CHART** must be connected for proper **ImageWriter** operation. Some pins may be NOCONN (no connects). In the sample **SETUP CHART** in [Figure 2-7](#), pins 5, 6, 9, 10, 13 and 14 are not connected.

NOTE: An example of connection for SPI protocol is shown on [page 7-8](#). An example of connection for Microchip serial protocol is shown on [page 7-9](#).

For IW-200 only: Once you have connected the USB cable from the computer to **IW-200** and supplied power, you can use CIL commands to control **IW-200**.

Control Interface Connections for Programming with IW-300

To use external signals to control **IW-300**, wire the Control Interface connector. Signals carried on this connector are optically isolated; therefore, your isolated references must be connected for the Control Interface to function. If you do not need to use isolation, **IW-300** power reference (5 V on pins 13 and 14) may be jumpered to the isolated supplies. For the Control Interface to start a Flow, at least these pins must be connected: four Flow select signals (pins 1, 2, 3, and 4), a start signal (pin 7), and the power references (pins 5, 6, 11, and 12).

To use external signals to control **IW-300**, complete this procedure.

NOTE: An external signal could be ATE pin-drivers, a hand operated switch, a mechanically actuated contact, or any other type of control that has a 5-24 V output range.

1. **Wire the 14-pin, 0.1 inch spacing, double row, female connector (supplied) to wires from a signal control as shown in Figure 2-8.**



Pin #	Pin Name	Pin Type	Description
1	SEL 1	Input	Isolated, Flow select input BIT0, 5-24 VDC, 20 mA max.
2	SEL 2	Input	Isolated, Flow select input BIT1, 5-24 VDC, 20 mA max.
3	SEL 4	Input	Isolated, Flow select input BIT2, 5-24 VDC, 20 mA max.
4	SEL 8	Input	Isolated, Flow select input BIT3, 5-24 VDC, 20 mA max.
5	Input GND	Ground	Isolated Input Ground
6	Input GND	Ground	Isolated Input Ground
7	START	Input	Isolated, Flow START, 5-24 VDC, 20 mA max.
8	RESET	Input	Isolated, Flow RESET, 5-24 VDC, 20 mA max.
9	PASS	Output	Isolated, Flow PASS, 25 mA max.
10	FAIL	Output	Isolated, Flow FAIL, 25 mA max.
11	PASS/FAIL V+	Power	Isolated Output V+ (24 V differential max.)
12	PASS/FAIL GND	Ground	Isolated Output Ground
13	VCC	Power	Non-isolated ImageWriter Sys. +5 V
14	GND	Ground	Non-isolated ImageWriter GND

Figure 2-8—Control Interface Connector Pin Chart

2. **Plug the connector into the Control Interface connector on IW-300.**

Three sample diagrams of Control Interface connections follow. The first (Figure 2-9) uses push buttons. The second (Figure 2-10) uses signals from Automatic Test Equipment to one IW-300. The third (Figure 2-11) uses signals from Automatic Test Equipment to Interconnected IW-300s.

Control Interface: IW-300 to Push Button Without Isolation

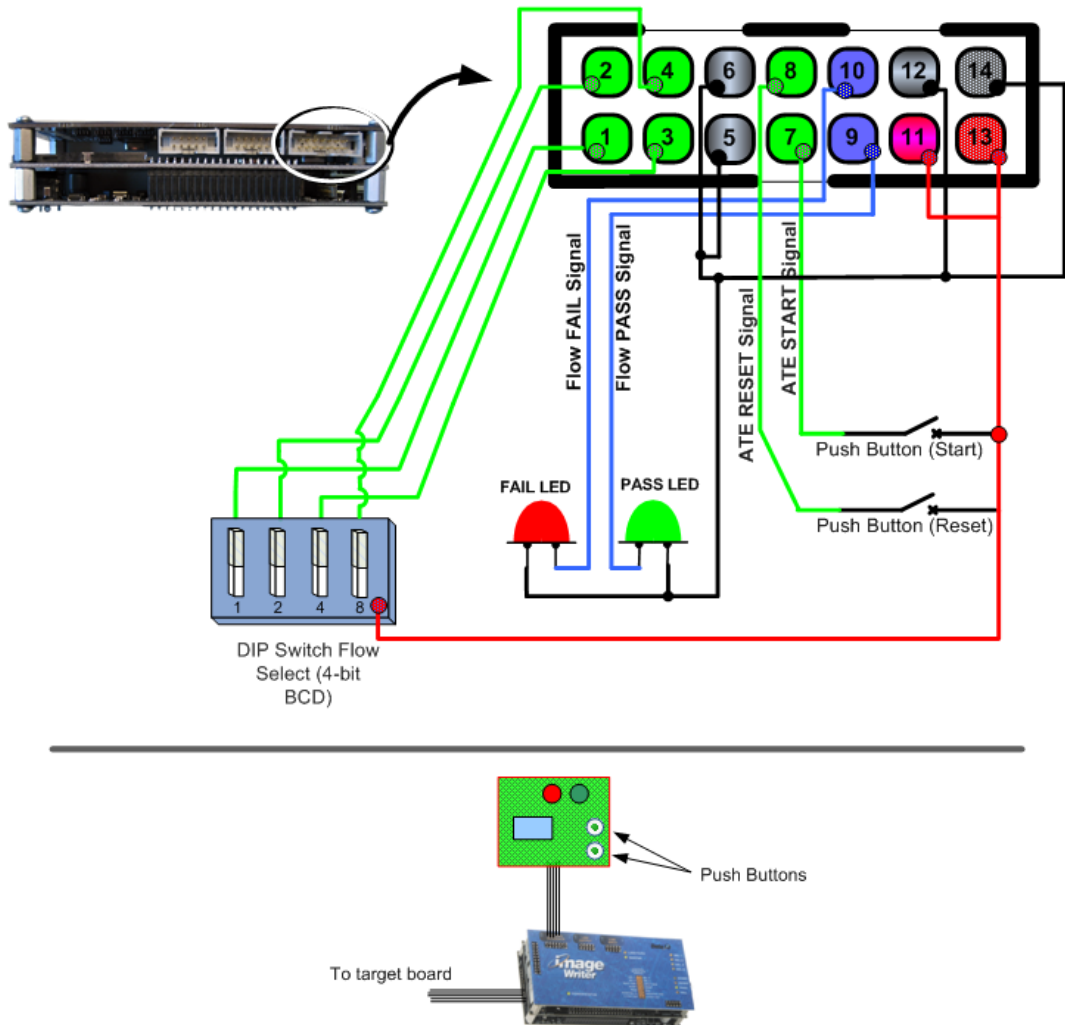

Figure 2-9—Push Button **Without** Isolation

Control Interface: IW-300 to ATE

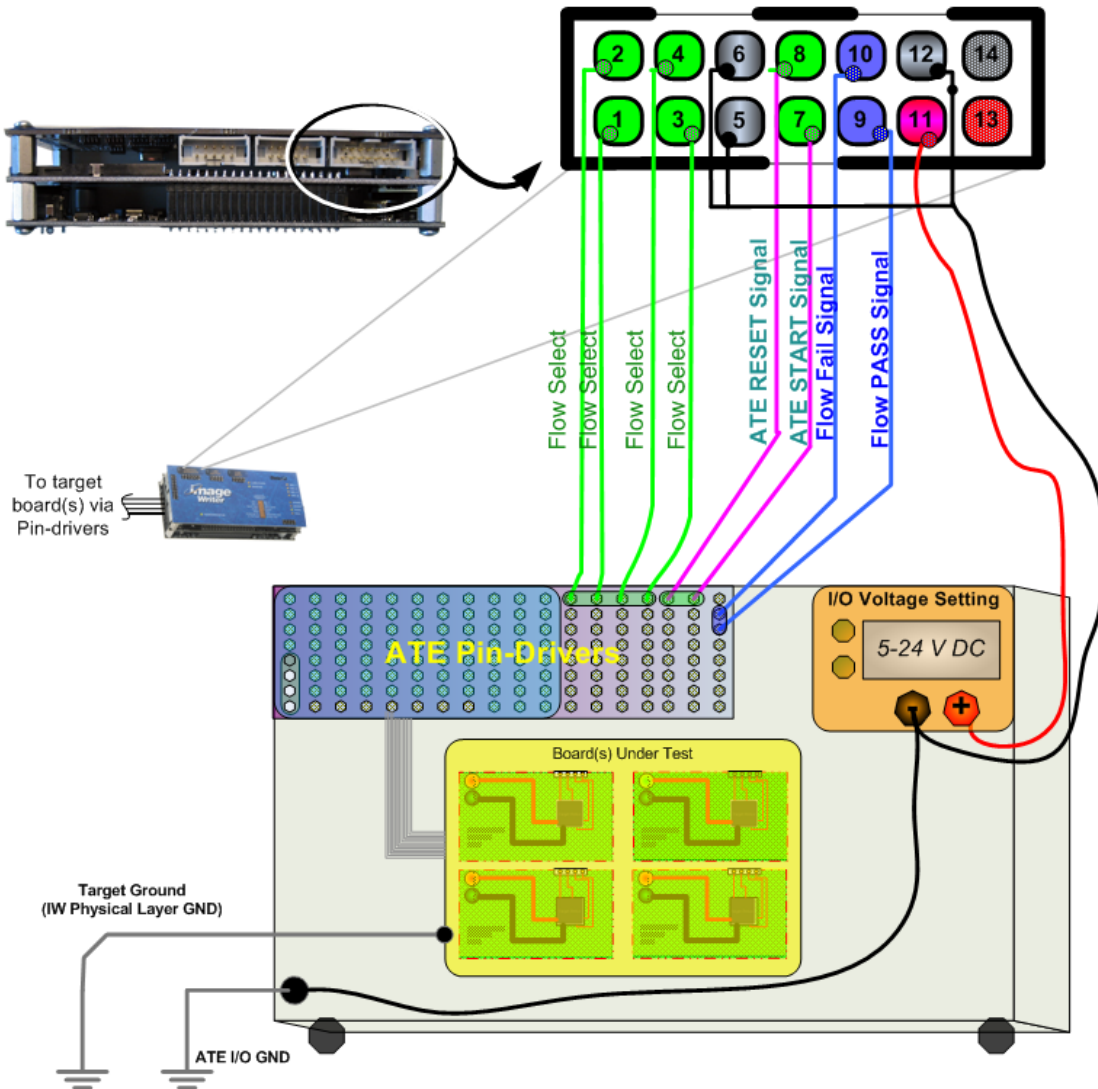

Figure 2-10—IW-300 to ATE

You can connect pins 9 and 10 to an input such as an ATE pin-driver, LED, I/O card or any other device that you want to monitor the pass/fail status of IW-300. The input and output reference connections on pins 5, 6, 11 and 12 must be connected for the ATE I/Os to function. The non-isolated Power/GND connections can be jumpered such that the isolation feature of the I/Os is not used.

Control Interface: Four Interconnected IW-300s to ATE

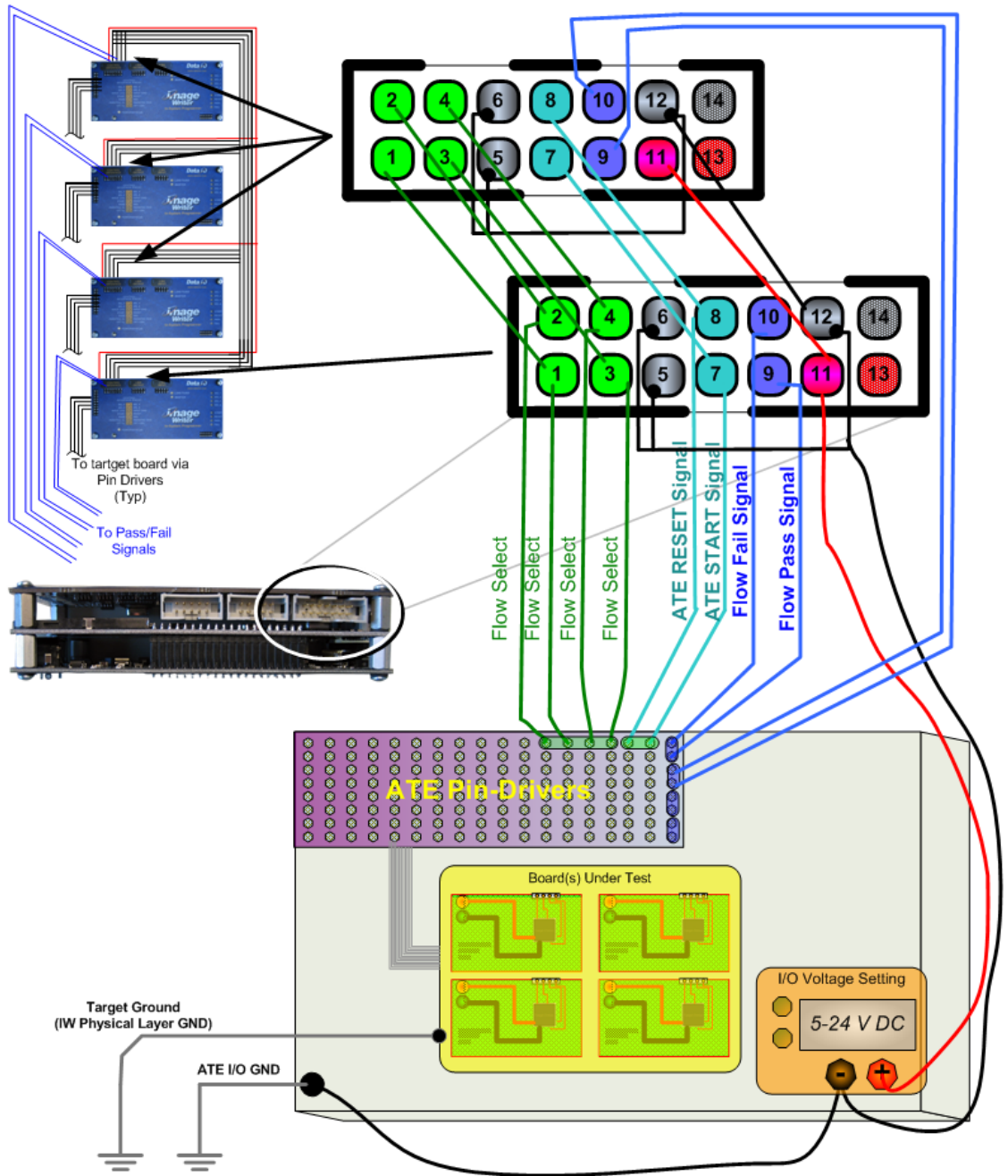
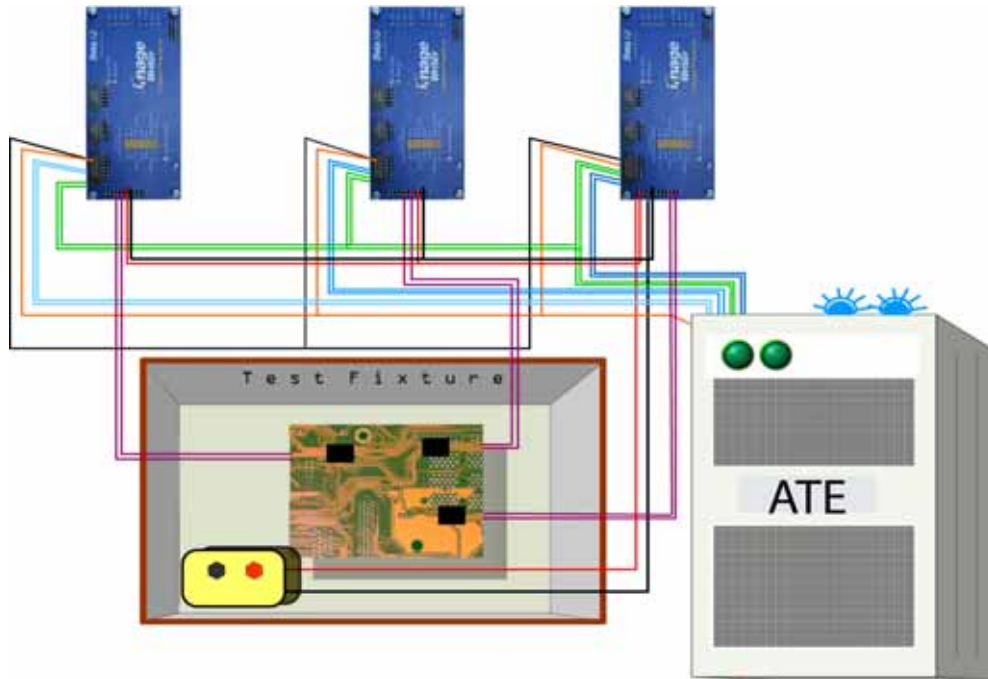

Figure 2-11—Four Interconnected IW-300s

Three Interconnected **ImageWriters-300s** — each programming a device on one target board in a test fixture using signals from Automatic Test Equipment — might look like **Figure 2-12**.



*Figure 2-12—
Interconnected **IW-300s** Power and Device Connections
(Blue = Pass/Fail
Green = Start/Reset
Red & Black = Power/Grnd
Magenta = Programming)*

Connections for Link Networking IW-300s for Configuration

To simultaneously download a device library or data file to multiple **IW-300s**, follow this procedure for setting up a Link Network.

With a Link Network (one master **IW-300** and up to 31 linked **IW-300s** on a single USB port), device libraries and data files can be sent to an individual **IW-300** or all **IW-300s** in the Link Network. Network address assignment is automatic and chain-position dependent. The network protocol is implemented over RS-485 differential pairs, allowing long cable runs if properly terminated.



CAUTION: Network connections should **not** be hot-swapped while power is applied to **IW-300**. Damage to **IW-300** might occur. Always remove power from the Link Network before adding or removing **IW-300s**.

NOTE: When configuring your **IW-300**, Data I/O recommends that you supply power by first plugging an AC Adapter into the round Auxiliary Power Connector on **IW-300's** Physical Layer, then plugging the other end into your power source.

For this procedure you need:

- an AC Adapter
- the USB cable (supplied)
- two or more female connectors (2-row, 10-pin, 0.1 inch centered, shrouded, and keyed)
- 10-conductor ribbon cable

1. **Assemble ribbon cables with 10-pin connectors on both ends.**

NOTE: Assemble one fewer ribbon cable than the number of **IW-300s** in the Link Network. For example, if the Link Network has 20 **IW-300s**, assemble 19 ribbon cables.

2. **Plug one end of a ribbon cable into the Link Output connector on the master IW-300.**
3. **Plug the other end of a ribbon cable into the Link Input connector on the next IW-300.**



Figure 2-13—Link Networked **ImageWriter-300s**: One Master **IW-300** and up to 31 Linked **IW-300s**

4. Continue to link together IW-300s in the Link Network using ribbon cables.
5. Plug the USB cable (supplied) into the USB connector on the Data Pump Layer of the master IW-300.

NOTE: The master **IW-300** will usually be the first **IW-300** in the daisy-chain.



Figure 2-14—Plug the USB Cable into **Master IW-300**

6. Plug the other end of the USB connector into your computer.
7. Provide power to the Link Network.
8. You can now configure your IW-300s using either:
 - **ImageWriter Tools** software on your **ImageWriter CD** (recommended). For more information, see **ImageWriter Tools Help**.
 - CIL commands via HyperTerminal (standard Windows® software).

NOTE: The Control Layer uses Opto-Isolators to provide electrical isolation. Therefore, even if your target board uses high voltage, you can connect your control input signal, such as ATE, to the Control Layer without damage. This is **NOT** true for the USB port.

Checking Communication

If you experience difficulty communicating with your **ImageWriter**, check communication using either method described below.

ImageWriter Tools Communication Check

1. Refresh the connected programmers by clicking **VIEW > REFRESH PROGRAMMERS**.
2. From the **USB tree**, select the programmer node you wish to check.
3. Click **SYNCH**.
Confirm that the command completes with no error message.
For more information, see **IW Tools Help**.

HyperTerminal Communication Check

1. Launch **HyperTerminal** from the **Windows Start menu (START > PROGRAMS > ACCESSORIES > COMMUNICATIONS)**.

NOTE: Before continuing, ensure that **ImageWriter** has power and is plugged into your **USB port**, and that the **Self-test** has finished. For more about the **Self-test** see **“Self-test on Power Up” on page 2-2**.

2. Enter a name, select an icon, and click **OK**.



Figure 2-15—Enter a Name, Select an Icon, and Click OK

3. In the **CONNECT To** window, click the **CONNECT USING** drop-down arrow and select the **COM** port that **ImageWriter** is connected on. Usually this is the highest numerical **COM** port listed.



Figure 2-16—**ImageWriter** Will Usually Be the Highest Number **COM** Port If You Just Plugged It into Your Computer

4. In the **COM[X] Properties** dialog, change to the default **IW** settings as shown in **Figure 2-17**. Click **OK**.

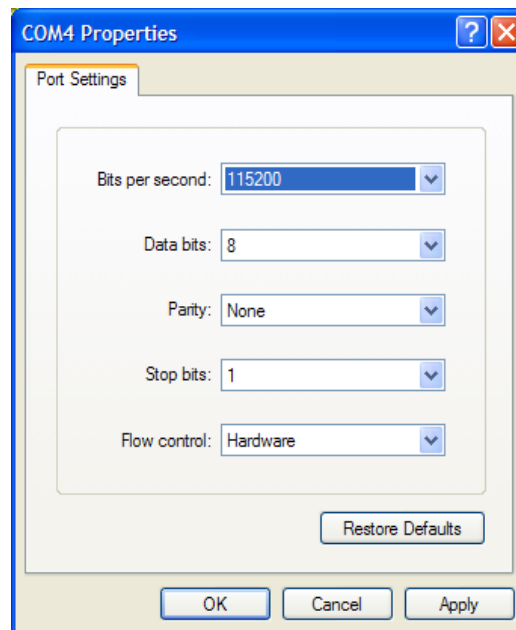

Figure 2-17—Factory Default Communications Settings for **IW** Are **115200, 8, None, 1, FLOW CONTROL** Should Read **Hardware**.

5. **For IW-300 only: To select an individual networked IW-300, send the command NSEL X (where X is the address of the networked IW-300). To select all networked IW-300s, send the command NALL.**
6. **After the connection has been made, repeatedly press the ENTER key. You should receive '>' prompt.**

If you still do **not** receive '>' prompt back from **ImageWriter** in HyperTerminal, check whether USB data is being transmitted. View USB data transmission LED D1 while pressing **ENTER**. LED D1 should blink during the USB data transaction. (It may only blink once or twice during short transactions.)

If LED D1 **does not** illuminate, HyperTerminal may be configured to an incorrect COM port. Reset to the correct COM port.

NOTE: *During prototyping and debugging, you can use the Terminal interface to directly control device Object operations on **ImageWriter**. The Terminal interface is menu-driven, rather than CIL command-driven, and can be useful for visualizing operations. A basic Memory viewer/editor that can access both Dynamic and Static memory areas is also available in the Terminal interface.*

3

Computer Interface Language (CIL) for IW-200

Computer Interface Language (CIL) controls **IW-200** to implement all activity including selecting and programming the target device and controlling Memory input and output operations. The CIL interface is generally compatible with environments that can send and receive data from a computer COM port, such as LabVIEW, Visual Basic, or C/C++.

CIL Syntax

CIL commands are made up of one or more command letters and may be followed by parameters. A space is required between the CIL command letter(s) and the parameter(s). Parameters contain hexadecimal numbers (or text) separated by a colon. Spaces are not permitted between parameters and the colon-separators.

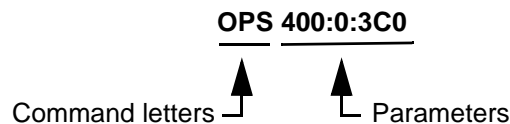

Figure 3-1—CIL Command Example

Responses to CIL Commands

Each time a CIL command is sent to **IW-200**, the module returns a CIL response. There is a one-to-one correspondence between CIL commands sent and CIL responses received. Between sending a CIL command and receiving the CIL response, text or data Input/Output may occur depending on the command sent. The two possible CIL responses are PASS or FAIL.

Response	Description
'>' (PASS)	The CIL command was successful. Ready for next command. NOTE: If the response contains data as well, the '>' character is sent after all data is sent.
'F' (FAIL)	The CIL command failed; an error has occurred.

Table 3-1—CIL Responses

Cancel Command

Pressing the **Esc** key causes **IW-200** to cancel its current operation and return a CIL response. However, there is an exception: pressing the **Esc** key during a binary Memory input operation does not cause **IW-200** to cancel because it is treated as data rather than as a command.

Errors

When a FAIL response occurs, an error code is always pushed onto a 16-level error stack. You cannot remove items or add items to the error stack, but you can read or clear it using CIL commands. For CIL commands to read or clear the error stack, see [“System Commands Table” on page 3-8](#). For a list of **IW-200** error codes, see [“IW-200 Numeric Error Codes \(Standard Errors\)” on page 5-1](#).

Memory Commands

IW-200 has two data storage areas: Dynamic Memory and Static Memory.

Dynamic Memory is implemented as SRAM and retains its contents until power is cycled to **IW-200**. Dynamic Memory is used for rapidly changing data such as serial numbers, or per-unit customized data. Dynamic Memory is a maximum of 16 Kilobytes in total size.

Static Memory is implemented in Compact Flash and retains its contents even when power is cycled to **IW-200**. Static Memory is used for storage of programming data, which does not change from device to device during manufacture.

NOTE: *Since Static Memory is implemented in Compact Flash, avoid using it for rapidly changing data because the total number of write-cycles has a lifetime rating. Read-cycles from Compact Flash are unlimited.*

Memory commands allow you to input to, or output from, any area of Static or Dynamic Memory. Two data formats are supported: binary (raw binary data) and hexadecimal. The maximum data amount that can be input or output per operation is 64 Kilobytes (0XFFFF bytes). However, as many Memory commands as needed can be issued consecutively to move a large amount of data.

Each Memory command contains in its syntax the source/destination Memory type (either Static or Dynamic Memory), and colon-separated parameters with **Memory Start** and **Size** parameters. Memory Start is always in hexadecimal bytes from the beginning of Dynamic or Static Memory. Size is always the number of hexadecimal bytes to input or output.

Only two memory formats, binary and hexadecimal, are supported by CIL Memory commands. Binary input is downloaded as absolute binary. Hexadecimal input must be formatted as two hexadecimal character values per byte. As soon as a Memory Input or Memory Output command is sent to **IW-200**, the data transfer is ready to begin. Following the data transfer (input or output) a four digit checksum and the PASS response ('>') are returned.

Memory Commands Table

Command A	Command B	Command C	Command D	Parameters	Example Syntax	Example Description
M (Memory)	I (Input)	S (Static) D (Dynamic)	H (Hex) B (Binary)	[Memory Begin: Size]	MISH 30:5	Input 0x5 bytes of Static Memory starting at address 0x30.
M	O (Output)	S D	H B	[Memory Begin: Size]	MODB 0:500	Output 0x500 bytes of Dynamic Memory starting at address 0.
M	F (Fill)	S D		[Memory Begin: Size:Fill Byte]	MFD 0:4000:00	Fill Dynamic Memory with 0x4000 bytes starting at address 0.
M ¹	S (Checksum)	S D		[Memory Begin: Size]	MSS 0:100	Checksum Static Memory from 0 for 0x100 bytes.
M	C (CRC-32)	S D		[Memory Begin: Size]	MCD 0:2FF	CRC-32 Dynamic Memory from 0 for 0x2FF bytes.

Table 3-2—IW-200 Memory Commands

¹ See “Checksum Calculations” on page 7-7 for additional information.

Object Commands

IW-200 supports the target device in segmented modules that represent logical data spaces or functions within the device. These segmented modules are referred to as device **Objects**. Your programming data is described across each **Object** as if it were a separate device. This makes it convenient to work with multiple data files or data sources for a single device. Examples of **Objects** include FLASH, LOCKBITS, EE, and ERASE. The exact names of the **Objects** for a given target device are shown in the **Object** chart contained in the Device Support Detail & Setup document. The size of most **Objects** is defined in bytes. However, devices that have 16-bit word data-spaces are defined in words. Object size is listed in the **Object** chart.

A sample **Object** chart from a Device Support Detail and Setup document is shown here:

Atmel ATmega128(L) Device Support Detail & Setup

ImageWriter Support Hierarchy

Manufacturer: Atmel

Device: ATMEGA128

Objects for ATMEGA128

SAMPLE ONLY

Object Name:	Program / Execute	Verify	Load	Object Size (Bytes)
FLASH	•	•	•	0x20000
EE	•	•	•	0x1000
LOCKBITS	•	•	•	1
FUSE BYTES	•	•	•	3
SIG BYTES			•	3
ERASE	•			
CALIB BYTE			•	1
p_SPI ¹	•		•	0x8

¹Default SPI clock frequency = 250KHz

Figure 3-2—Sample **Object** Chart

IW-200 supports three general Object commands that can be executed on an **Object**.

- **Program / Execute:** Program (or execute without data, *i.e.*, Erase) the currently selected device **Object** with data from Static or Dynamic Memory
- **Verify:** Verify the currently selected device **Object** against data in Static or Dynamic Memory
- **Load:** Load the currently selected device **Object** into either Static or Dynamic Memory

Object commands are used to perform device operations and can only be issued after both a **Manufacturer:Device** pair and a specific **Object** have been selected. Load, Program, and Verify commands might not be available for all **Object** types. For example, for the device ATMEGA128, you can Load the **Object** CALIB BYTE, but you cannot Program/Execute or Verify the **Object** CALIB BYTE. See [Figure 3-2](#).

Object command syntax specifies the Memory source (Static or Dynamic) for each Object command issued. Colon-separated parameters follow the command with **Memory Start** (always in hexadecimal bytes from the beginning of Dynamic or Static Memory), **Object Start** (specified in device-width of **Object**, from **Object** offset in the physical device), and **Size** (specified in the device-width and indicating the number of bytes or words to process).

Based on the CIL response to the Object command, the Status LED (D2) will rapidly blink RED (for FAIL) or GREEN (for PASS). The status will remain on the Status LED until either the next Object command is sent or **IW-200** is reset.

Object Commands Table

Command A	Command B	Command C	Parameters	Example Syntax ¹	Purpose
O (Object)	L (Load)	S (Static) D (Dynamic)	[Memory Begin: Object Begin: Size]	OLD 5:0:10	Load 10 hex bytes from 0 (beginning) of Object to 0x05 of Dynamic Memory
O	P (Program or Execute)	S D	[Memory Begin: Object Begin: Size]	OPS 0:1F0:800	Program 800 hex bytes (or words) from 0 (beginning) of Static Memory starting at Object address 0x1F0
O	V (Verify)	S D	[Memory Begin: Object Begin: Size]	OVD FF:0:2000	Verify 2000 hex bytes (or words) starting from 0 (beginning) of Object against Dynamic Memory starting at address 0xFF
O	D (Device Select)		[Manufacturer: Device]	OD ATMEL:ATTiny26	Select Manufacturer Atmel and device ATTiny26
O	S (Object Select)		[Object]	OS FLASH	Select Object FLASH

Table 3-3—IW-200 Object Commands

¹ A space is required between the CIL command letter and the parameters. Press **ENTER** after all syntax statements.

System Commands

System commands are used to control **IW-200** functionality, check versions, and retrieve error status.

System Commands Table

Command A	Parameters	Syntax Example	Purpose
SEL		SEL	List most recent error code
SELD		SELD	List most recent error code with details
SEH		SEH	List last 16 error codes
SEHD		SEHD	List last 16 error codes with details
SEHC		SEHC	Clear all errors
SEOD¹		SEOD	Show most recent Object verify error details. Message format is "Object Address:ExpectedData:ActualData"
SRST		SRST	Reset IW-300
SVER		SVER	List system version
SVERD		SVERD	List system version with details
SINFO		SINFO	Dump debugging information

Table 3-4—IW-200 System Commands

¹ If you attempt to examine an Object verify error using SEOD prior to an occurrence of "Error 0x811: Verify Object Failed," the returned message data will be invalid and spurious.

Terminal Mode Commands

Terminal mode is a built in interface that allows for menu-driven control of **IW-200** without using the more syntax-sensitive CIL command set. Terminal mode is useful for both prototyping and debugging when working with **IW-200**. When Terminal mode is started, **IW-200** will not respond to further CIL commands until Terminal mode is exited. Therefore, exit Terminal mode prior to sending additional CIL commands.

Executed CIL commands affect the menu context (*i.e.*, Manufacturer, Device, Object, Memory-type, Parameters) within Terminal mode. Therefore, you may hand-enter a CIL command and check its post operation results by starting Terminal mode. This can be useful for debugging or prototyping.

Terminal mode also includes a memory editor that allows viewing and editing of both Static and Dynamic Memory. The editor is accessible inside Terminal mode or directly via a CIL command.

Terminal Mode Commands Table

Command	Purpose
TE ¹	Run built in memory editor
TM	Run built in Terminal interface

Table 3-5—IW-200 Terminal Commands

¹ The memory editor displays data in byte addresses regardless of the selected **Object's** addressing size.

CIL Example

The flowchart in **Figure 3-3** shows logical steps and example CIL syntax (in red) that can be used for most processes. Note that intermediate CIL responses are not shown except for the "Check result of operation" step after the OPS 0:0:800 programming command.

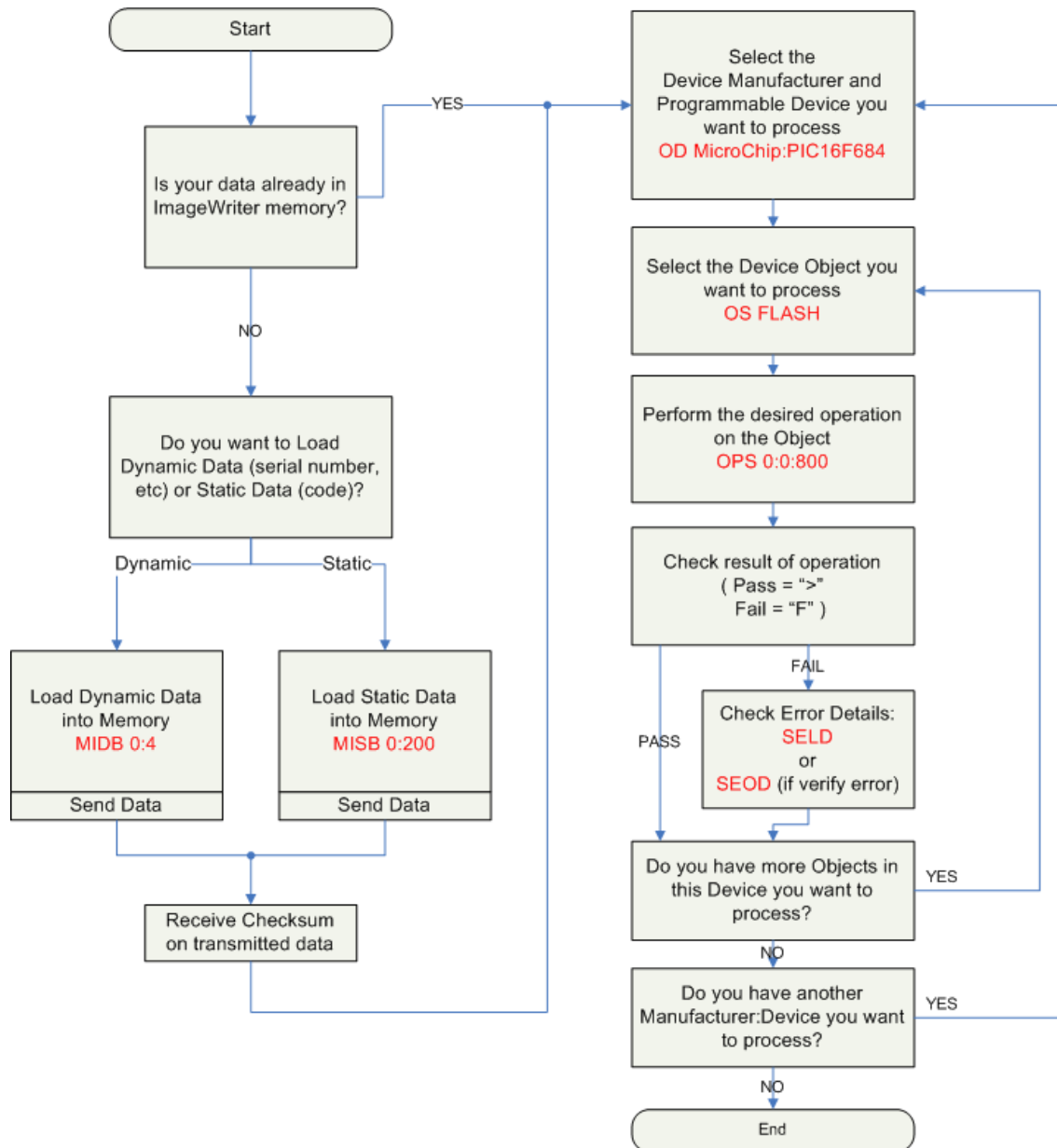

Figure 3-3—CIL Example

4

Computer Interface Language (CIL) for IW-300

Computer Interface Language (CIL) controls **IW300** to implement all activity including selecting and programming the target device and controlling Memory input and output operations. The CIL interface is generally compatible with environments that can send and receive data from a computer COM port, such as LabVIEW, Visual Basic, or C/C++.

Memory, Object, System and Terminal mode (**MOST**) commands used to control **IW-300** are the same as those used to control **IW-200**. In addition to the MOST commands, **IW-300** has Flow (**F**) and Network (**N**) commands. For Flow commands, see “[Flow Commands](#)” on page 4-10. For Network commands, see “[Network Commands](#)” on page 4-12.

CIL Syntax

CIL commands are made up of one or more command letters and may be followed by parameters. A space is required between the CIL command letter(s) and the parameter(s). Parameters contain hexadecimal numbers (or text) separated by a colon. Spaces are not permitted between parameters and the colon-separators.

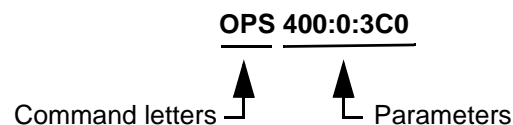

Figure 4-1—CIL Command Syntax Example

Responses to CIL Commands

Each time a CIL command is sent to **IW-300**, the module returns a CIL response. There is a one-to-one correspondence between CIL commands sent and CIL responses received. Between sending a CIL command and receiving the CIL response, text or data Input/Output

may occur depending on the command sent. The two possible CIL responses are PASS or FAIL.

Response	Description
'> (PASS)	The CIL command was successful. Ready for next command. NOTE: If the response contains data as well, the '>' character is sent after all data is sent.
'F' (FAIL)	The CIL command failed; an error has occurred.

Table 4-1—CIL Responses

Cancel Command

Pressing the **Esc** key causes **IW-300** to cancel its current operation and return a CIL response. However, there is an exception: pressing the **Esc** key during a binary Memory input operation does not cause **IW-300** to cancel because it is treated as data rather than as a command.

Errors

When a FAIL response occurs, an error code is always pushed onto a 16-level error stack. You cannot remove items or add items to the error stack, but you can read or clear it using CIL commands. For CIL commands to read or clear the error stack, see [“System Commands Table” on page 4-8](#). For a list of **IW-300** error codes, see [“IW-300 Numeric Error Codes \(Standard Errors\)” on page 6-1](#).

Memory Commands

IW-300 has two data storage areas: Dynamic Memory and Static Memory:

- **Dynamic Memory** is implemented as SRAM and retains its contents until power is cycled to **IW-300**. Dynamic Memory is used for rapidly changing data such as serial numbers, or per-unit customized data. Dynamic Memory is a maximum of 16 Kilobytes in total size.
- **Static Memory** is implemented as Compact Flash and retains its contents even when power is cycled to **IW-300**. Static Memory is used for storage of programming data, which does not change from unit to unit during manufacture.

NOTE: *Since Static Memory is implemented as Compact Flash, avoid using it for rapidly changing data because the total number of write-cycles has a lifetime rating. Read-cycles from Compact Flash are unlimited.*

Memory commands allow you to input to, or output from, any area of Static or Dynamic Memory. Two data formats are supported: binary (raw binary data) and hexadecimal. The maximum data amount that can be input or output per operation is 64 Kilobytes (0XFFFF bytes). However, as many Memory commands as needed can be issued consecutively to move a large amount of data.

Each Memory command contains in its syntax the source/destination Memory type (either Static or Dynamic Memory), and colon-separated parameters with **Memory Start** and **Size** parameters. Memory Start is always in hexadecimal bytes from the beginning of Dynamic or Static Memory. Size is always the number of hexadecimal bytes to input or output.

Only two memory formats, binary and hexadecimal, are supported by CIL Memory commands. Binary input is downloaded as absolute binary. Hexadecimal input must be formatted as two hexadecimal character values per byte. As soon as a Memory input or Memory output command is sent to **IW-300**, the data transfer is ready to begin. Following the data transfer (input or output) a four digit checksum and the PASS response ('>') are returned.

Memory Commands Table

Command A	Command B	Command C	Command D	Parameters	Example Syntax	Example Description
M (Memory)	I (Input)	S (Static) D (Dynamic)	H (Hex) B (Binary)	[Memory Begin: Size]	MISH 30:5	Input 0x5 bytes of Static Memory starting at address 0x30.
M	O (Output)	S D	H B	[Memory Begin: Size]	MODB 0:500	Output 0x500 bytes of Dynamic Memory starting at address 0.
M	F (Fill)	S D		[Memory Begin: Size:Fill Byte]	MFD 0:4000:00	Fill Dynamic Memory with 0x4000 bytes starting at address 0.
M ¹	S (Checksum)	S D		[Memory Begin: Size]	MSS 0:100	Checksum Static Memory from 0 for 0x100 bytes.
M	C (CRC-32)	S D		[Memory Begin: Size]	MCD 0:2FF	CRC-32 Dynamic Memory from 0 for 0x2FF bytes.

Table 4-2—IW-300 Memory Commands

¹ See “Checksum Calculations” on page 7-7 for additional information.

Object Commands

IW-300 supports the target device in segmented modules that represent logical data spaces or functions within the device. These segmented modules are referred to as device **Objects**. Your programming data is described across each **Object** as if it were a separate device. This makes working with multiple data files or data sources for a single device convenient. Examples of **Objects** include FLASH, LOCKBITS, EE, and ERASE. The exact names of the **Objects** for a target device are shown in the **Object** chart contained in the Device Support Detail & Setup document. The size of most **Objects** is defined in bytes. However, devices that have 16-bit word data-spaces are defined in words. Object size is listed in the **Object** chart:

Atmel ATmega128(L) Device Support Detail & Setup

ImageWriter Support Hierarchy

Manufacturer: Atmel

Device: ATMEGA128

Objects for ATMEGA128

SAMPLE ONLY

Object Name:	Program / Execute	Verify	Load	Object Size (Bytes)
FLASH	•	•	•	0x20000
EE	•	•	•	0x1000
LOCKBITS	•	•	•	1
FUSE BYTES	•	•	•	3
SIG BYTES			•	3
ERASE	•			
CALIB BYTE			•	1
p_SPI ¹	•		•	0x8

¹ Default SPI clock frequency = 250KHz

Figure 4-2—Sample **Object** Chart

IW-300 supports three general Object commands that can be executed on an **Object**:

- **Program / Execute:** Program (or execute without data, *i.e.*, Erase) the currently selected device **Object** with data from Static or Dynamic Memory
- **Verify:** Verify the currently selected device **Object** against data in Static or Dynamic Memory
- **Load:** Load the currently selected device **Object** into either Static or Dynamic Memory

Object commands are used to perform device operations and can only be issued after both a **Manufacturer:Device** pair and a specific **Object** have been selected. Load, Program, and Verify commands might not be available for all **Object** types. For example, on device

ATMEGA128, you can Load the **Object** CALIB BYTE, but you cannot Program/Execute or Verify the **Object** CALIB BYTE. See [Figure 4-2](#).

Object command syntax specifies the Memory source (Static or Dynamic) for each Object command issued. Colon-separated parameters follow the command with **Memory Start** (always in hexadecimal bytes from the beginning of Dynamic or Static Memory), **Object Start** (specified in device-width of **Object**, from **Object** offset in the physical device), and **Size** (specified in the device-width and indicating the number of bytes or words to process).

Based on the CIL response to the Object command, the Status LED (D2) will rapidly blink RED (for FAIL) or GREEN (for PASS) and will remain until the next Object command is sent or **IW-300** is reset.

Object Commands Table

Command A	Command B	Command C	Parameters	Example Syntax ¹	Purpose
O (Object)	L (Load)	S (Static) D (Dynamic)	[Memory Begin: Object Begin: Size]	OLD 5:0:10	Load 10 hex bytes from 0 (beginning) of Object to 0x05 of Dynamic Memory
O	P (Program or Execute)	S D	[Memory Begin: Object Begin: Size]	OPS 0:1F0:800	Program 800 hex bytes (or words) from 0 (beginning) of Static Memory starting at Object address 0x1F0
O	V (Verify)	S D	[Memory Begin: Object Begin: Size]	OVD FF:0:2000	Verify 2000 hex bytes (or words) starting from 0 (beginning) of Object against Dynamic Memory starting at address 0xFF
O	D (Device Select)		[Manufacturer: Device]	OD ATMEL:ATTiny26	Select Manufacturer Atmel and device ATTiny26
O	S (Object Select)		[Object]	OS FLASH	Select Object FLASH

Table 4-3—IW-300 Object Commands

¹ A space is required between the CIL command letter and the parameters. Press **ENTER** after all syntax statements.

System Commands

System commands are used to control **IW-300** functionality, check versions, and retrieve error status.

System Commands Table

Command A	Parameters	Syntax Example	Purpose
SEL		SEL	List most recent error code
SELD		SELD	List most recent error code with details
SEH		SEH	List last 16 error codes
SEHD		SEHD	List last 16 error codes with details
SEHC		SEHC	Clear all errors
SEOD¹		SEOD	Show most recent Object verify error details. Message format is "Object Address:ExpectedData:ActualData"
SRST		SRST	Reset IW-300
SVER		SVER	List system version
SVERD		SVERD	List system version with details
SINFO		SINFO	Dump debugging information

Table 4-4—IW-300 System Commands

¹ If you attempt to examine an Object verify error using SEOD prior to an occurrence of "Error 0x811: Verify Object Failed," the returned message data will be invalid and spurious.

Terminal Mode Commands

Terminal mode is a built in interface that allows for menu-driven control of **IW-300** without using the more syntax-sensitive CIL command set. Terminal mode is useful for both prototyping and debugging when working with **IW-300**. When Terminal mode is started, **IW-300** will not respond to further CIL commands until Terminal mode is exited. Therefore, exit Terminal mode prior to sending additional CIL commands.

Executed CIL commands affect the menu context (*i.e.*, Manufacturer, Device, Object, Memory-type, Parameters) within Terminal mode. Therefore, you may hand-enter a CIL command and check its post operation results by starting Terminal mode. This can be useful for debugging or prototyping.

Terminal mode also includes a memory editor that allows viewing and editing of both Static and Dynamic Memory. The editor is accessible inside Terminal mode or directly via a CIL command.

Terminal Mode Commands Table

Command	Purpose
TE ¹	Run built in memory editor
TM	Run built in Terminal interface

Table 4-5—IW-300 Terminal Commands

¹ The memory editor displays data in byte addresses regardless of the selected **Object's** addressing size.

Flow Commands

"Flow" refers to the steps to accomplish a programming process. A Flow can be thought of as a script that executes commands needed to program a target device. Commands could include Object operations (such as Program, Verify, or Load), Memory operations (such as Checksum or CRC-32), System operations (such as checking a specific **IW-300** error code), or others. Before a Flow can be run, it must be sent to one of 16 Flow positions in **IW-300**. Up to 16 separate Flows can be stored in **IW-300** hardware.

Flow CIL commands provide the ability to run a Flow via the USB interface. A Flow can also be started using the Control Interface. A single Flow can execute many hundreds of CIL commands in sequence. Most device programming processes require 8-12 steps; however, more complex operations can be easily accommodated.

A Flow can have Object commands that map to either Static or Dynamic Memory. Before starting a Flow, the data that is addressed must be in **IW-300** Memory. Data can be downloaded by **IW Tools**, or by an external control system using CIL Memory commands.

Flows have a 16-level Flow error stack which includes an error code and a text description.

Data I/O's **IW Tools** is used to create Flows and download them to **IW-300**. Flow files have a .fld extension.

Flow Commands Table

Command A	Parameters	Syntax Example	Purpose
FRUN	[Flow # 0-0xF] ¹	FRUN B	Run Flow 11
FSTOP	[Network address 0-0x1F]	FSTOP 1A	Stop a currently running Flow
FINF	[Flow # 0-0xF]	FINF 0	List Flow information for Flow 0
FIMS		FIMS	Show last Flow command
FIMR		FIMR	Show last Flow response
FELN		FELN	Show line number of most recent Flow error
FEL		FEL	List most recent Flow error code
FELD		FELD	List most recent Flow error code with details
FEH		FEH	List last 16 Flow error codes
FEHD		FEHD	List last 16 Flow error codes with details
FEHC		FEHC	Clear all Flow errors

Table 4-6—**IW-300** Flow Commands

¹ Flow numbers are entered as hexadecimal values.

Flow Example

The chart below shows an example of running a Flow on **IW-300**.

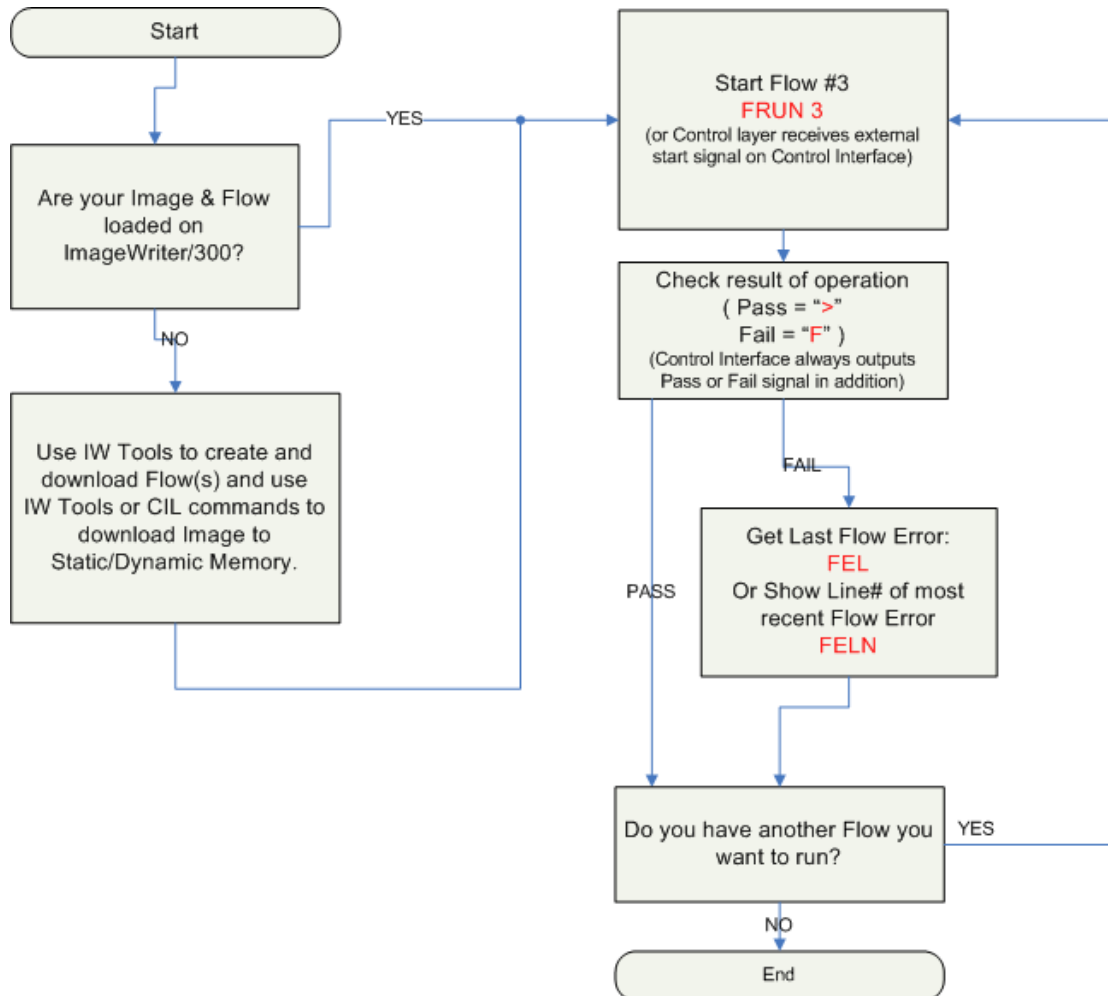

Figure 4-3—**IW-300** Flow Example

Network Commands

IW-300 network commands provide a simple method of synchronizing programming operations and data movement across multiple **IW-300** units. Each **IW-300** in a network is automatically assigned an address by hardware when power is applied. Network-Link status can be observed on the LED visible from the top of the **IW-300** unit.

The **IW-300** in the network that has an active USB connection is designated the master **IW-300** and is assigned the network ID of 0 (zero). Subsequent units are assigned the next network addresses incrementally. If two or more **IW-300s** in the same network have active USB connections, the first USB connection in the chain becomes the master **IW-300**.

Network Commands Table

Command A	Parameters	Syntax Example	Purpose
NRST		NRST	Reset network
NALL		NALL	Address all IW-300s in network
NSEL	[Network address 0-0x1F] ¹	NSEL 1C	Address an individual IW-300 in network
NPNG	[Network address 0-0x1F]	NPNG 1C	Ping for status of individual IW-300 in network
NIMR		NIMR	Show last network result
NVER		NVER	Show network version
NVERD		NVERD	Show network version with details
NINFO		NINFO	List detailed network information

Table 4-7—**IW-300** Network Commands

¹ Addresses are entered as hexadecimal values.

Network Operation

The **IW-300** network has two modes of operation: an individual unit on the network may be selected, or all units in the network may be selected. If all units in the network are selected, CIL responses come from the master **IW-300** only.

CIL commands that address a specific unit (such as FSTOP X or NPNG X), do not return a response (">" or "F") if a unit with that address does not actually exist in the network. For example, if a network contains Unit 0 to Unit 7 and you send the command NPNG 9, you receive no response.

To query or control a single **IW-300**, simply address that unit with NSEL X and send commands as normal. To select all units in the network again, send the network command NALL.

It is also possible to have a network where no units are selected. **IW-300s** that are not selected do not respond to CIL commands. You can visually determine if a unit is selected by checking the Power/Status LED on the Control Layer.



Figure 4-4—Power/Status LED

- If the Power/Status LED is solid, the **IW-300** is not selected.
- If the Power/Status LED is blinking, the **IW-300** is selected and will respond to CIL commands.

To select a unit, you must issue the NSEL X or NALL command before sending any other CIL commands. **This applies even to a single IW-300 that has no additional networked units.**

NPNG Command Response

The network ping command (NPNG) provides a way to check the status of an **IW-300** at any time. NPNG is especially useful to determine if a module exists and is not busy before selecting that module with NSEL X. In addition to reporting status, NPNG also returns the status of the previously executed Flow, and the total number of CIL commands received.

Sending the NPNG command deselects the **IW-300** and returns a response as follows:

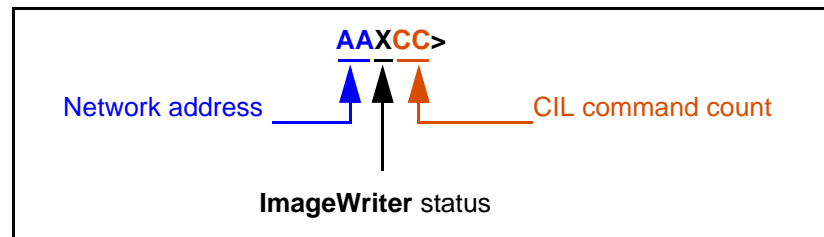

Figure 4-5—CIL Response to NPNG Command

For example, a response to *NPNG 1C* might be *1CR23*>

	Explanation	Example
Network address	The network address of this ImageWriter in hexadecimal value. (For example, 1C is ImageWriter #30 in the network)	1C
ImageWriter status	<ul style="list-style-type: none"> • R (ready) • B (busy) • F (ready, but most recent Flow failed) 	R
CIL command count	A hexadecimal number that increments for each CIL command this ImageWriter receives	23

Figure 4-6—Responses to *NPNG* Command

Deselecting IW-300s

Running certain network and Flow commands will deselect **IW300s** on a network.

NOTE: This applies even to a single **IW-300** that has no additional networked **IW-300s**.

Additionally, certain CIL commands will function regardless of the network selection state of an **IW-300**.

The table below shows commands that deselect an **IW-300** and whether the command requires the **IW-300** to be selected.

Command	Description	Drop network selection ?	Requires unit to be selected ?
FRUN [Flow#]	Run Flow	YES	YES
FSTOP [Network address]	Stop a currently running Flow	YES	NO
NPNG [Network address]	Ping for status of IW-300	YES	NO

Figure 4-7—Command Effect on Network Selection

Network Command Examples

Default Network Status

No **IW-300s** are selected. This is the default network status immediately after **IW-300s** are powered up or after a Flow is run.

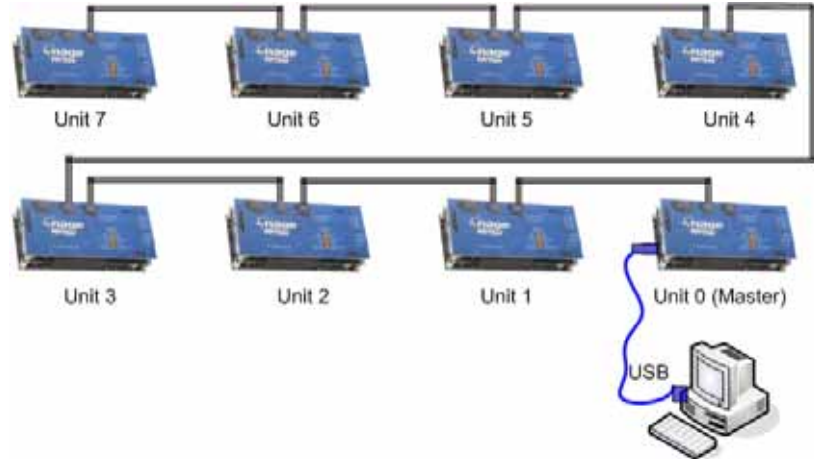

Figure 4-8—Default Network Status (No **IW-300s** Selected)

CIL Command: NSEL 0

CIL Command NSEL 0 selects Unit 0. Any other previously selected units are deselected.

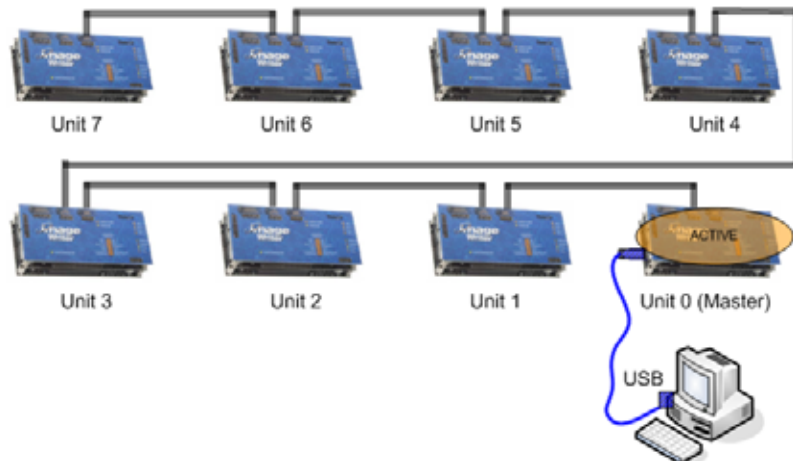

Figure 4-9—NSEL 0

CIL Command: NSEL 6

CIL Command NSEL 6 selects Unit 6 only. Any other previously selected units are deselected.

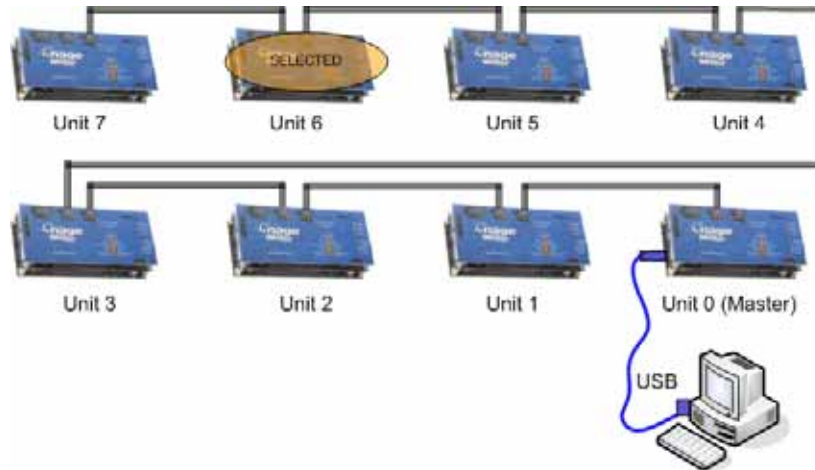

Figure 4-10—NSEL 6

CIL Command: NALL

CIL Command NALL selects all units in network. The master IW-300 provides CIL responses in this mode. All units receive identical commands and/or data.

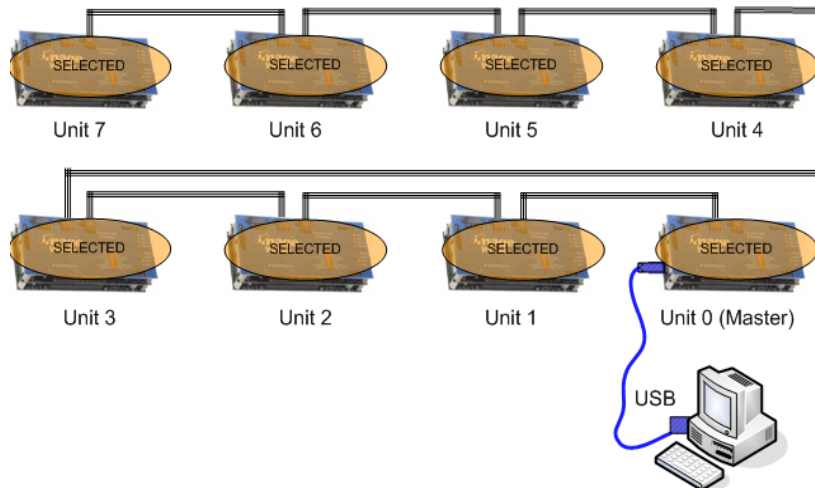

Figure 4-11—NALL

No Address Assigned

All units prior to the **IW-300** with the USB connection (the master **IW-300**) are not assigned a network address.

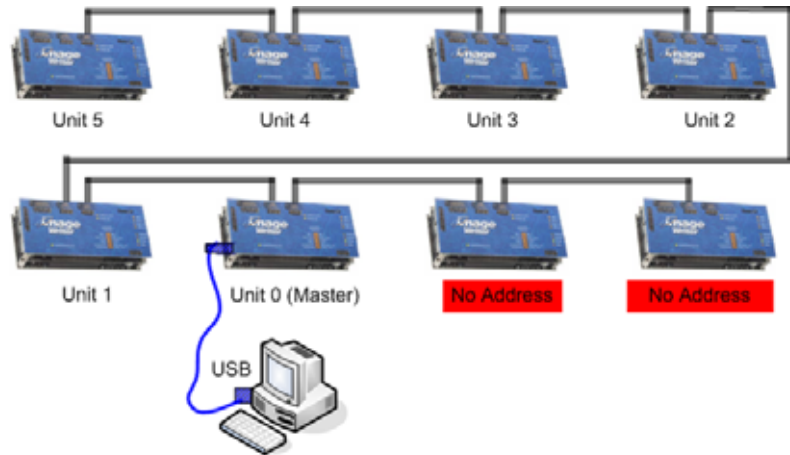

Figure 4-12—No Address

CIL Command: NPNG 3

CIL Command NPNG 3 pings Unit 3. The ping result from Unit 3 will be returned. NPNG causes all units to be deselected. The result is a network with no units selected.

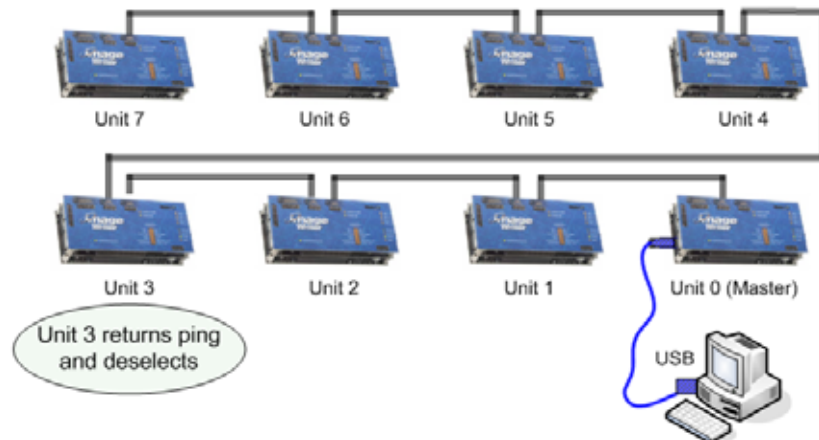

Figure 4-13—NPNG 3

CIL Command Sequence: NALL, FRUN 0, NPNG 7

The sequence of CIL Commands (NALL, FRUN 0, NPNG 7) results as follows:

- CIL Command NALL selects all units in network.
- CIL Command FRUN 0 causes all selected units to run Flow 0. After receiving the FRUN 0 command, all selected units drop off the network and begin executing the Flow.
- CIL Command NPNG 7 (sent while the Flow is running) returns a Busy response. Continued NPNG 7 commands will indicate when Unit 7 is finished executing Flow 0. Busy/Ready status

on other units can be checked with additional NPNG commands.

NOTE: The execution time of a Flow may vary based on the device being programmed or if **IW-300s** are loaded with dissimilar Flows.

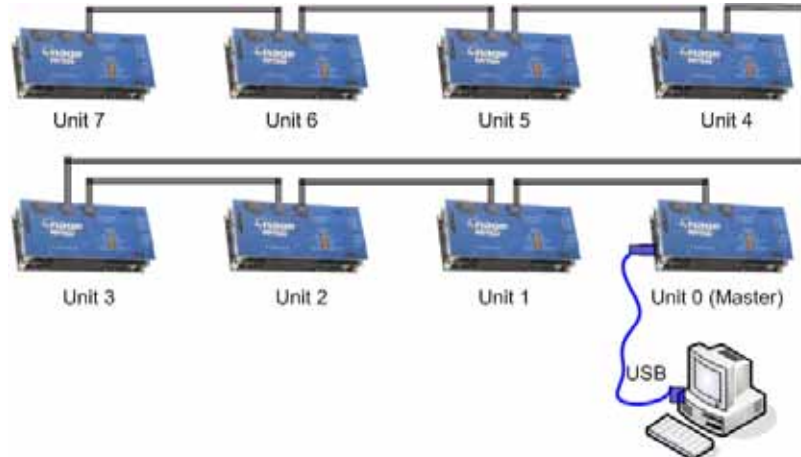

Figure 4-14—Deselected Units Busy Running Flow

5

IW-200 Errors

When a FAIL response is returned on **IW-200**, an error has occurred. There are two types of errors:

- **Standard Errors:** The Status LED (D2 on the Data Pump) blinks RED rapidly and a numeric error code is added to the 16-level error stack. See [IW-200 Numeric Error Codes \(Standard Errors\)](#) below for a list of numeric error codes and detailed descriptions.
- **High-Priority Errors:** The Status LED (D2 on the Data Pump) blinks between 2 and 8 times, with a pause of 1.5 seconds between each cycle of the blink pattern. No numeric error code is added to the error stack. In most cases, a high priority error renders **IW-200** non-responsive until the error condition is resolved. See [“Data Pump Error Blink Pattern \(High Priority Errors\)” on page 5-3](#) for high priority error descriptions and possible solutions.

IW-200 Numeric Error Codes (Standard Errors)

Error Category	Code	Error Text
	0x0001	No Error
Data Pump System	0x0100	Generic datapump error
	0x0101	System reset cycle
Data Pump Memory	0x0200	Generic memory error
	0x0201	Memory card not detected
	0x0202	Memory card not compatible
Physical Layer Hardware	0x0300	Generic physical layer error
	0x0301	Pin driver overcurrent occurred during operation
	0x0302	Physical layer driver error during operation

Error Category	Code	Error Text (<i>continued</i>)
Communication I/O	0x0500	Generic communications error
	0x0501	Invalid parameters for selected command
	0x0502	Extra characters following command
	0x0503	Device manufacturer not found
	0x0504	Device name not found
	0x0505	No valid device selected
	0x0506	Device object not found
	0x0507	Parameter 1 out of range
	0x0508	Parameter 2 out of range
	0x0509	Parameter 3 out of range
	0x0510	Operation canceled
	0x0511	Invalid command
	0x0512	Non-hexadecimal data in input stream
Image	0x0700	Generic image error
	0x0701	Operation exceeds system memory size
	0x0702	Operation timed out
	0x0703	Format not properly terminated
Object	0x0800	Generic algorithm error
	0x0801	No object selected
	0x0802	Invalid image parameters for selected object
	0x0803	Load function not supported for selected object
	0x0804	Program function not supported for selected object
	0x0805	Verify function not supported for selected object
	0x0806	Expanded function not supported for selected object

Error Category	Code	Error Text (<i>continued</i>)
Object (<i>continued</i>)	0x0807	Selected object init function failed
	0x0808	Selected object close function failed
	0x0809	Load object failed
	0x0810	Program object failed
	0x0811	Verify object failed
	0x0812	Expanded operation on object failed
	0x0813	No partial block limits can be set on this object
General System	0x0900	Generic device error

Table 5-1—**IW-200** Numeric Error Codes

Data Pump Error Blink Pattern (High Priority Errors)

For High Priority errors, the Status LED (D2 on the Data Pump) blinks between 2 and 8 times, with a pause of 1.5 seconds between each cycle of the blink pattern.

Error Blink Pattern	Error Text	Solution
2 blinks	Memory Card not present	Insert Memory Card
3 blinks	Memory Card not compatible	Contact Data I/O
4 blinks	SRAM error / General system fault	Contact Data I/O
5 blinks	Physical Layer not compatible	Contact Data I/O
6 blinks	Application code not present	Use IW Tools to download device library
7 blinks	Memory error	Contact Data I/O
8 blinks	Control Layer not compatible	Contact Data I/O

Table 5-2—**IW-200** Data Pump Layer High Priority Error Blink Pattern

6

IW-300 Errors

When a FAIL response is returned on **IW-300**, an error has occurred. There are two types of errors:

- **Standard Errors:** The Status LED (D2 on the Data Pump) blinks RED rapidly and a numeric error code is added to the 16-level error stack. See [IW-300 Numeric Error Codes \(Standard Errors\)](#) below for a list of numeric error codes and detailed descriptions.
- **High-Priority Errors:** The Status LED (D2 on the Data Pump) blinks between 2 and 8 times, with a pause of 1.5 seconds between each cycle of the blink pattern. No numeric error code is added to the error stack. In most cases, a high priority error renders **IW-300** non-responsive until the error condition is resolved. See [“Data Pump Layer Error Blink Pattern \(High Priority Errors\)”](#) on page 6-5 for high priority error descriptions and possible solutions.

IW-300 Numeric Error Codes (Standard Errors)

Error Category	Code	Error Text
	0x0001	No Error
Data Pump System	0x0100	Generic datapump error
	0x0101	System reset cycle
Data Pump Memory	0x0200	Generic memory error
	0x0201	Memory card not detected
	0x0202	Memory card not compatible

Error Category	Code	Error Text (continued)
Physical Layer Hardware	0x0300	Generic physical layer error
	0x0301	Pin driver overcurrent occurred during operation
	0x0302	Physical layer driver error during operation
Communication I/O	0x0500	Generic communications error
	0x0501	Invalid parameters for selected command
	0x0502	Extra characters following command
	0x0503	Device manufacturer not found
	0x0504	Device name not found
	0x0505	No valid device selected
	0x0506	Device object not found
	0x0507	Parameter 1 out of range
	0x0508	Parameter 2 out of range
	0x0509	Parameter 3 out of range
	0x0510	Operation canceled
	0x0511	Invalid command
	0x0512	Non-hexadecimal data in input stream
Flow	0x0600	Generic flow error
	0x0601	Premature end of file; no END found
	0x0602	Instruction not recognized
	0x0603	missing "="
	0x0604	missing "/" on comment
	0x0605	Flow too large to fit in memory
	0x0606	Flow sumcheck error
	0x0607	Flow size differs from header
	0x0608	Parameter too long
	0x0609	Parameter invalid

Error Category	Code	Error Text (continued)
Flow (continued)	0x0610	Flow input timeout error
	0x0611	Invalid parameters for selected command
	0x0612	Extra characters following command
	0x0613	Programmer missing LF on received response
	0x0614	Programmer not responding to sync command
	0x0617	Parameter 1 out of range
	0x0618	Parameter 2 out of range
	0x0619	Parameter 3 out of range
	0x0620	Function terminated by control interface
	0x0621	Function terminated by software control
	0x0625	Invalid command
	0x0640	Internal communication failure
	0x0641	Internal communication timeout error
	0x0642	Flow differs from programmer response
	0x0643	Extra characters in expected response
	0x0698	Flow checksum error
0x0699	Flow parser version incompatible with flow	
Image	0x0700	Generic image error
	0x0701	Operation exceeds system memory size
	0x0702	Operation timed out
	0x0703	Format not properly terminated
Object	0x0800	Generic algorithm error
	0x0801	No object selected

Error Category	Code	Error Text (continued)
Object (continued)	0x0802	Invalid image parameters for selected object
	0x0803	Load function not supported for selected object
	0x0804	Program function not supported for selected object
	0x0805	Verify function not supported for selected object
	0x0806	Expanded function not supported for selected object
	0x0807	Selected object init function failed
	0x0808	Selected object close function failed
	0x0809	Load object failed
	0x0810	Program object failed
	0x0811	Verify object failed
	0x0812	Expanded operation on object failed
	0x0813	No partial block limits can be set on this object
	General System	0x0900

Table 6-1—IW-300 Numeric Error Codes

Data Pump Layer Error Blink Pattern (High Priority Errors)

For High Priority errors, the Status LED (D2 on the Data Pump) blinks between 2 and 8 times, with a pause of 1.5 seconds between each cycle of the blink pattern.

Error Blink Pattern	Error Text	Solution
2 blinks	Memory Card not present	Insert Memory Card
3 blinks	Memory Card not compatible	Contact Data I/O
4 blinks	SRAM error / General system fault	Contact Data I/O
5 blinks	Physical Layer not compatible	Contact Data I/O
6 blinks	Application code not present	Use IW Tools to download device library
7 blinks	Memory error	Contact Data I/O
8 blinks	Control Layer not compatible	Contact Data I/O

Table 6-2—**IW-300** Data Pump Layer High Priority Error Blink Pattern

Control Layer Error Blink Pattern (High Priority Errors)

For High Priority errors, the FAIL LED on the Control Layer blinks a pattern, with a pause of 1.5 seconds between each cycle of the blink pattern.

Error Blink Pattern	Error Text
2 blinks	Memory error
3 blinks	Host communication error
4 blinks	General system fault

Table 6-3—**IW-300** Control Layer High Priority Error Blink Pattern

7

ImageWriter Reference

Data Pump Layer

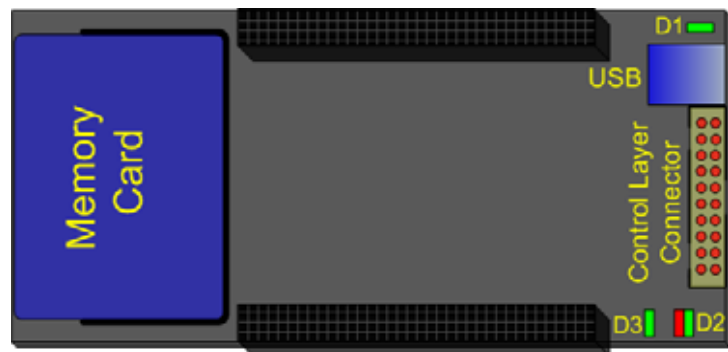

Figure 7-1—Data Pump

Feature	Description
Memory Card	The Memory Card is installed at the factory and provides mass storage for data. Though socketed, it is NOT intended to be removed by the customer. You cannot directly access the Memory Card via your computer. For information about Memory Card replacement, contact Data I/O. CAUTION: After a Memory Card is put into ImageWriter , the card is no longer usable by a computer or other consumer devices.
USB Connector	Type B USB connector used to connect ImageWriter to a computer using the USB cable (supplied).
Control Layer Connector	Control Layer Connector is used to connect the Data Pump to the optional Control Layer. IW-200 only: There are factory-installed jumpers on this connector. DO NOT remove these jumpers.
USB Data LED (D1)	Indicates if USB data channel is actively transmitting.
Status LED (D2)	A multi-color LED: <ul style="list-style-type: none"> • GREEN indicates Pass/Okay • RED indicates Error • Flashing YELLOW indicates waiting to send communication • Solid YELLOW indicates a device operation is in progress For high-priority errors, Status LED blinks an error code. For IW-200 , see “Data Pump Error Blink Pattern (High Priority Errors)” on page 5-3. For IW-300 , see “Data Pump Layer Error Blink Pattern (High Priority Errors)” on page 6-5.
Data Pump Power LED (D3)	Indicates +5 V system power is being provided to Data Pump.

Table 7-1—Data Pump Features

Physical Layer

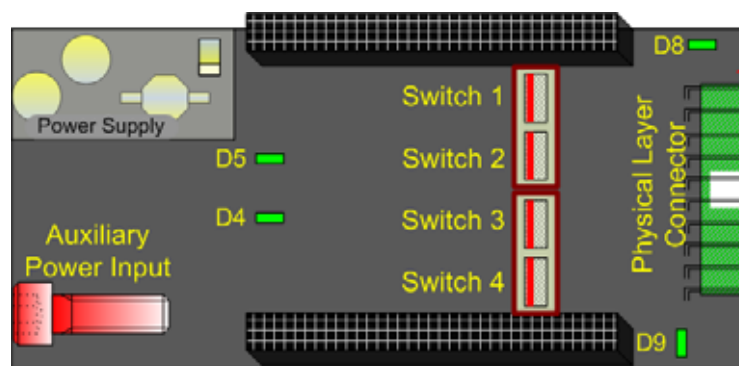

Figure 7-2—Physical Layer

Physical Layer Feature	Description
Physical Layer Connector	Target Board Programming Signal and System Power Connector.
Switch 1	RXD RS-232 Switch. If this switch is set toward the power supply (factory default) it will switch TTL levels on RXD/MISO input. If the switch is set toward the Physical Layer Connector it will switch RS-232 levels on RXD/MISO. DO NOT change default setting.
Switch 2	CTS RS-232 Switch. If this switch is set toward the power supply (factory default) it will switch TTL levels on CTS input. If the switch is set toward the Physical Layer Connector it will switch RS-232 levels on CTS. DO NOT change default setting.
Switch 3	TXD/RTS RS-232 Switch. If this switch is set toward the power supply (factory default) it will switch TTL levels on TXD and RTS outputs. If the switch is set toward the Physical Layer Connector it will switch RS-232 levels on TXD and RTS. DO NOT change default setting.
Switch 4	I2C pull-up control. If this switch is set toward the power supply (factory default) it will not provide a 10KOhm pull-up on the programmer's I2C bus. If the switch is set toward the Physical Layer Connector it will apply a 10KOhm pull-up for cases where the target board does not provide its own I2C pull-up. DO NOT change default setting.
Regulator LED (D4)	Indicates if V Target+ is being regulated to 4.2 V (LED ON), or if V Target+ is being passed-through (LED OFF).
Overcurrent LED (D5)	Indicates if an overcurrent condition has occurred.
VPP/EXT_ON LED (D8)	Indicates if VPP/EXT input is being switched to the VPP/EXT output on the Physical Layer Connector.
Power Physical Layer (D9)	Indicates +5 V system power is being provided to the Physical Layer.
Auxiliary Power Input	This connector provides an alternate power connection for ImageWriter . 9-24 VDC input. 2.1 mm power jack.

Table 7-2—Physical Layer Features

Physical Layer Connector

The Physical Layer Connector on the Physical Layer provides 20 pins for making connections from **ImageWriter** to the target system.



Figure 7-3—Physical Layer Connector

Pin #	Pin Name	Pin Type	Description
1	GND	Ground	Programmer Electrical Ground
2	GND	Ground	Programmer Electrical Ground
3	TXD (MOSI/TDO)	Output	Output Driver
4	RXD (MISO/TDI)	Input	Input Driver
5	RTS (TMS)	Output	Output Driver
6	CTS	Input	Input Driver
7	XCLK	Output	Output Driver
8	RST	Output	Output Driver
9	SCL	Output	I2C SCL Driver
10	SDA	Input/Output	I2C SDA Driver
11	GND	Ground	Programmer Electrical Ground
12	GND	Ground	Programmer Electrical Ground
13	VPP/EXT_IN	Power, Input	VPP/External Voltage Input (max. 24V)
14	VPP-EXT_OUT	Power, Output	VPP/External Voltage Output (max. 24V)
15	Target V+	Power, Input	Target Board Voltage Level Input (1.5 - 7.0V max.)
16	Target V+	Power, Input	Target Board Voltage Level Input (1.5 - 7.0V max.)
17	GND	Ground	Programmer Electrical Ground
18	GND	Ground	Programmer Electrical Ground
19	POWER	Power, System	Programmer Power Supply Input (9-24 VDC)
20	POWER	Power, System	Programmer Power Supply Input (9-24 VDC)

Table 7-3—Physical Layer Connector Pin Descriptions

Control Layer

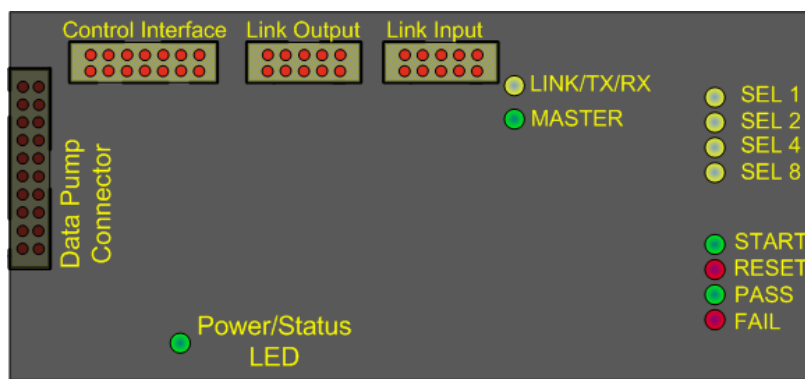

Figure 7-4—Control Layer

Feature	Description
Power/Status LED	Green LED indicates IW-300 power and status — Solid green: IW-300 is not network active Solid w/ slow blink: IW-300 is active on network (NALL) Fast blink: IW-300 is the selected module on network (NSEL x)
LINK/TX/RX	Yellow LED indicates linked status — Solid yellow: IW-300 has successfully arbitrated network address. Off: IW-300 does not have valid network address, or no master is on the daisy-chain.
MASTER	Green LED indicates network master status — Solid green: IW-300 has active USB connection and is network master [Note: Link LED will be off if unit is master]. Off: IW-300 does not have active USB connection.
SEL 1	Yellow LED Flow Select Bit 0 lights if BIT0 is active (selected) on Control Interface.
SEL 2	Yellow LED Flow Select Bit 1 lights if BIT1 is active (selected) on Control Interface.
SEL 4	Yellow LED Flow Select Bit 2 lights if BIT2 is active (selected) on Control Interface.
SEL 8	Yellow LED Flow Select Bit 3 lights if BIT3 is active (selected) on Control Interface.
START	Green LED lights if start signal is active on Control Interface.
RESET	Red LED lights if RESET signal is active on Control Interface.
PASS	Green LED lights if most recent Flow passed.
FAIL	Red LED lights if most recent Flow failed.

Table 7-4—Control Layer Features

Control Interface Connector



Figure 7-5—Control Interface Connector

Pin #	Pin Name	Pin Type	Description
1	SEL 1	Input	Isolated, Flow select input BIT0, 5-24 VDC, 20 mA max.
2	SEL 2	Input	Isolated, Flow select input BIT1, 5-24 VDC, 20 mA max.
3	SEL 4	Input	Isolated, Flow select input BIT2, 5-24 VDC, 20 mA max.
4	SEL 8	Input	Isolated, Flow select input BIT3, 5-24 VDC, 20 mA max.
5	Input GND	Ground	Isolated Input Ground
6	Input GND	Ground	Isolated Input Ground
7	START	Input	Isolated, Flow START, 5-24 VDC, 20 mA max.
8	RESET	Input	Isolated, Flow RESET, 5-24 VDC, 20 mA max.
9	PASS	Output	Isolated, Flow PASS, 25 mA max.
10	FAIL	Output	Isolated, Flow FAIL, 25 mA max.
11	PASS/FAIL V+	Power	Isolated Output V+ (24 V differential max.)
12	PASS/FAIL GND	Ground	Isolated Output Ground
13	VCC	Power	Non-isolated ImageWriter Sys. +5 V
14	GND	Ground	Non-isolated ImageWriter GND

Figure 7-6—Control Interface Pin Descriptions

The Control Interface provides a method to control **IW-300** without a computer. Isolated inputs for *Start*, *Pass* and 4-bit Job-Select are provided. Isolated outputs for Pass/Fail status are also provided. Status of the Control Interface inputs and outputs is also indicated by LEDs visible from the top of **IW-300**.

Hardware

The Control Interface is provided on the 14-pin, .1" centered, shrouded and keyed connector on the Control Layer. Because the Control Interface is optically isolated it requires input/output reference GND/V+ levels be connected on pins 12 and 11. If you want to use the ATE Interface, but do not require isolated inputs, you may jumper the provided, non-isolated GND/VCC connections on pins 14 and 13 on the Control Interface connector. See the reference section for more information and diagrams on how to configure the optoisolated pin-connections.

Physical Connections

To use the Control Interface, connect the CONTROL I/O input pins 1, 2, 3, 4, 7, 8 as appropriate to a signal control. These controls could be ATE pin-drivers, a hand operated switch, a mechanically actuated contact, or any other type control that has a 5-24 V output range.

You may connect pins 9 and 10 to an output, which could be a ATE pin-driver, LED, I/O card or any other device that you want to monitor the status of **IW-300**. The isolated input and output reference connections on pins 9, 10, 11, and 12 must be connected for the ATE I/Os to function. You may jumper the non-isolated Power/GND connections if you do not require the isolation feature of the I/Os.

Network Interface (Hardware)

IW-300 implements a proprietary network that allows for up to 32 **IW-300s** to be linked together. The network can be issued CIL commands, data files, or device libraries over a single USB connection. When a network is formed, a single **IW-300** may be addressed or the entire network may be addressed. Network address assignment is automatic and chain-position dependent, providing for fast in-network hardware replacements without software control changes. The network protocol is implemented over RS-485 differential pairs, allowing long cable runs if properly terminated.



CAUTION: Network connections should **not** be hot-swapped while power is applied to **IW-300**. Damage to **IW-300** might occur. Always remove power from the network before adding or removing **IW-300s**.

The Network interfaces are provided on two, 10-pin, .1" centered, shrouded and keyed connectors on the Control Layer. A separate connector is provided for both Link Input and Link Output connections.

To create a network of **IW-300s**, connect the Network Output connector from the first **IW-300** to the Network Input connector of the next **IW-300**. Repeat the network connections in a daisy-chain style for the remainder of the network, up to 32 units.



CAUTION: Do **not** loop the network output connector on the final **IW-300** back to the network input connector on the first **IW-300**.

The master **IW-300** is determined by which **IW-300** you plug the USB connection into. The pin-connection is mirrored between the input and output connectors, providing for easy pin-matching.

IW-300 Start Up

When power is applied to **IW-300**, the Data Pump starts its Self-test cycle. Simultaneously, the Control Layer also starts its Self-test cycle and **IW-300** begins initialization. During initialization the Control Interface LEDs cycle rapidly from top to bottom. Both the Control Layer and the Data Pump Layer must finish their Self-test cycles before **IW-300** will respond to USB communications. Under normal conditions, **IW-300** is fully initialized within 10 seconds.

An error condition has occurred if the Data Pump Status LED (D2) indicates normal operation while the Control Interface LEDs are still cycling rapidly. Contact Data I/O if this occurs.

Checksum Calculations

ImageWriter does not return a CRC-32 after a Memory Input operation. Instead, it returns a standard checksum after each Memory Input operation, or via the MSS or MSD CIL commands. A CRC-32 is only obtained by running an explicit CIL command: MCS or MCD.

The standard checksum is performed by initializing the checksum to zero, summing all data into the checksum, inverting the checksum, and adding 1.

The C pseudo code to represent this is:

```
Unsigned Int CalculateChecksum(Unsigned Int BlockSize, Unsigned Char *Data)
{
    Unsigned Int CheckSum = 0;

    While(BlockSize)
    {
        CheckSum += *Data++;
        BlockSize--;
    }

    CheckSum = (~CheckSum) + 1;

    return CheckSum;
}
```

Setup Example: SPI Protocol

ImageWriter-200 Setup Example for SPI Interface

(This is an example. Your specific setup requirements may vary.)

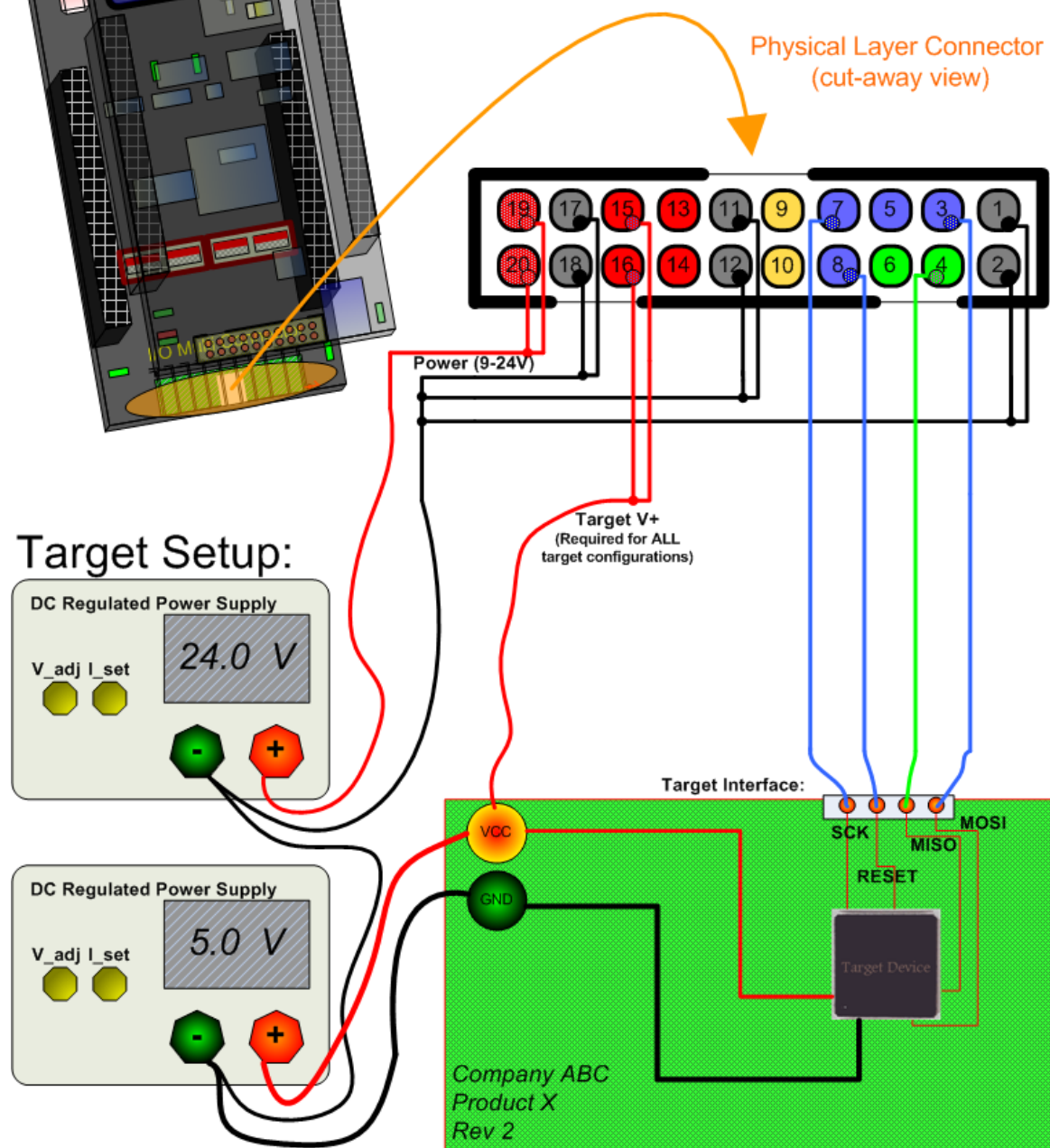

Figure 7-7—Setup Example for SPI Protocol

Setup Example: Microchip Serial Protocol

ImageWriter Setup Example for MCT-Microchip PIC Serial Interface

(This is an example. Your specific setup requirements may vary.)

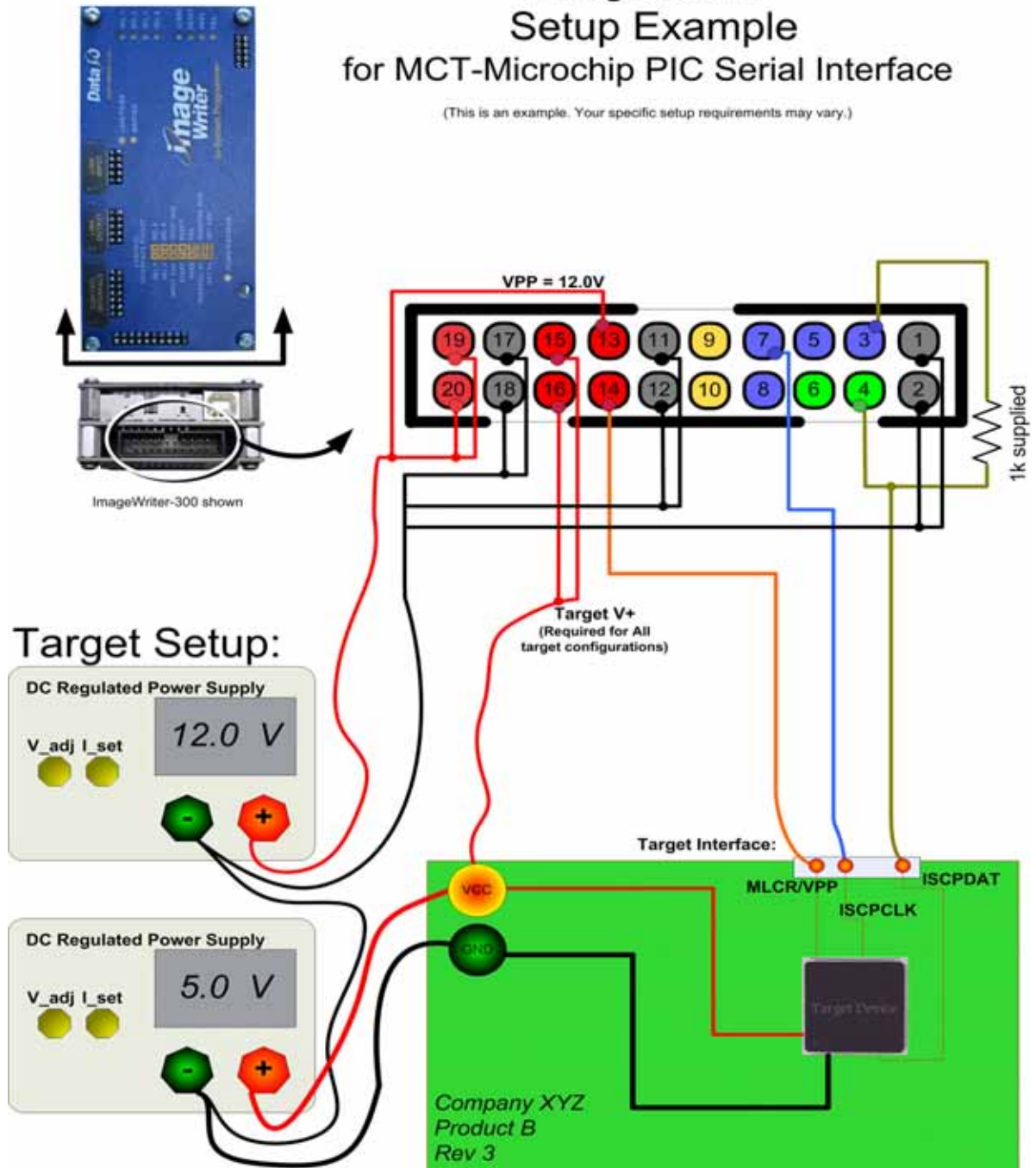

Figure 7-8—Setup Example for Microchip Serial Protocol

Setup Example: Control Interface to ATE

Control Interface Setup Example:

ATE Machine /w Optoisolation
 (This is an example, your specific setup requirements may vary)

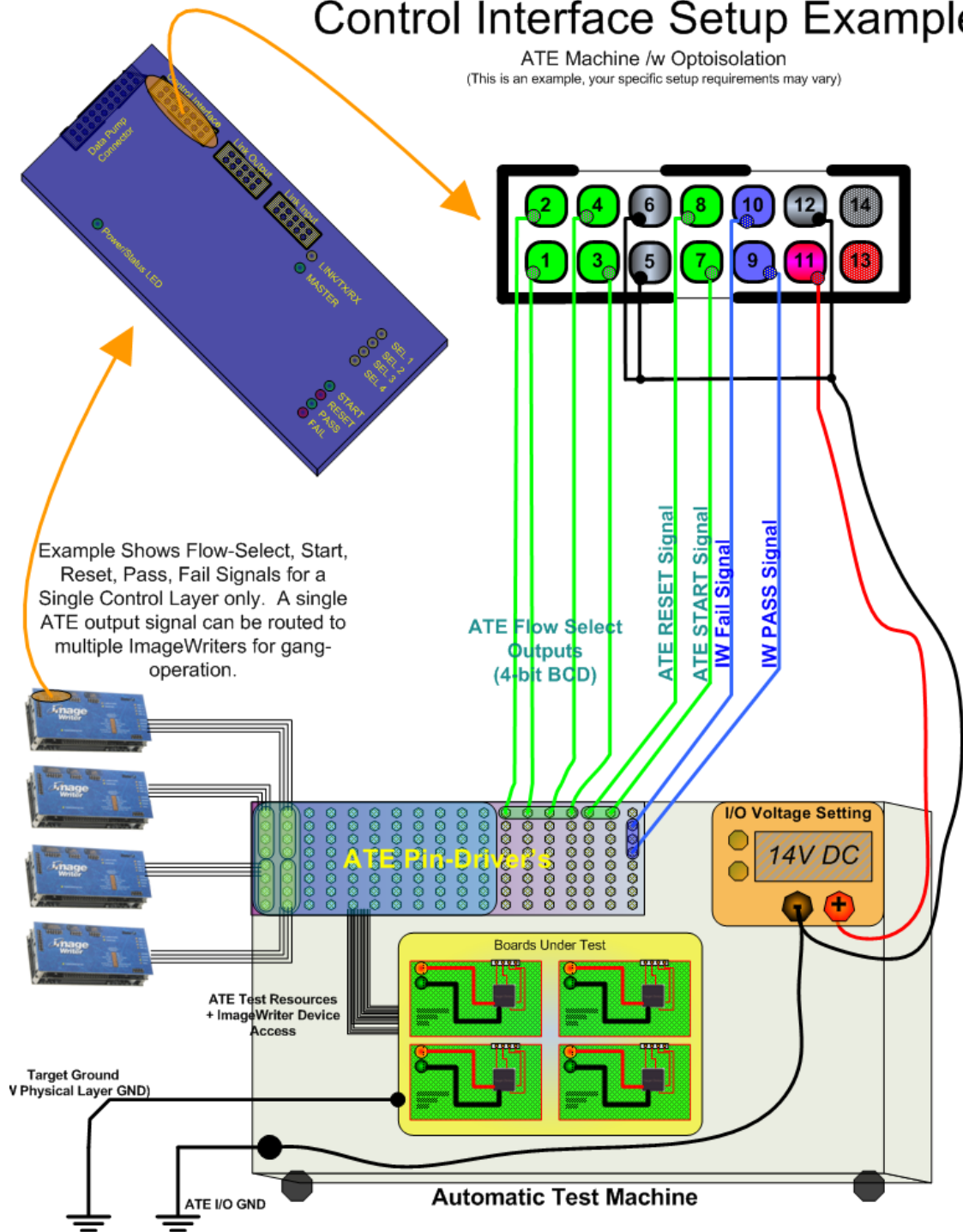

Figure 7-9—Setup Example for Control Interface to ATE

Setup Example: Control Interface to Push Buttons

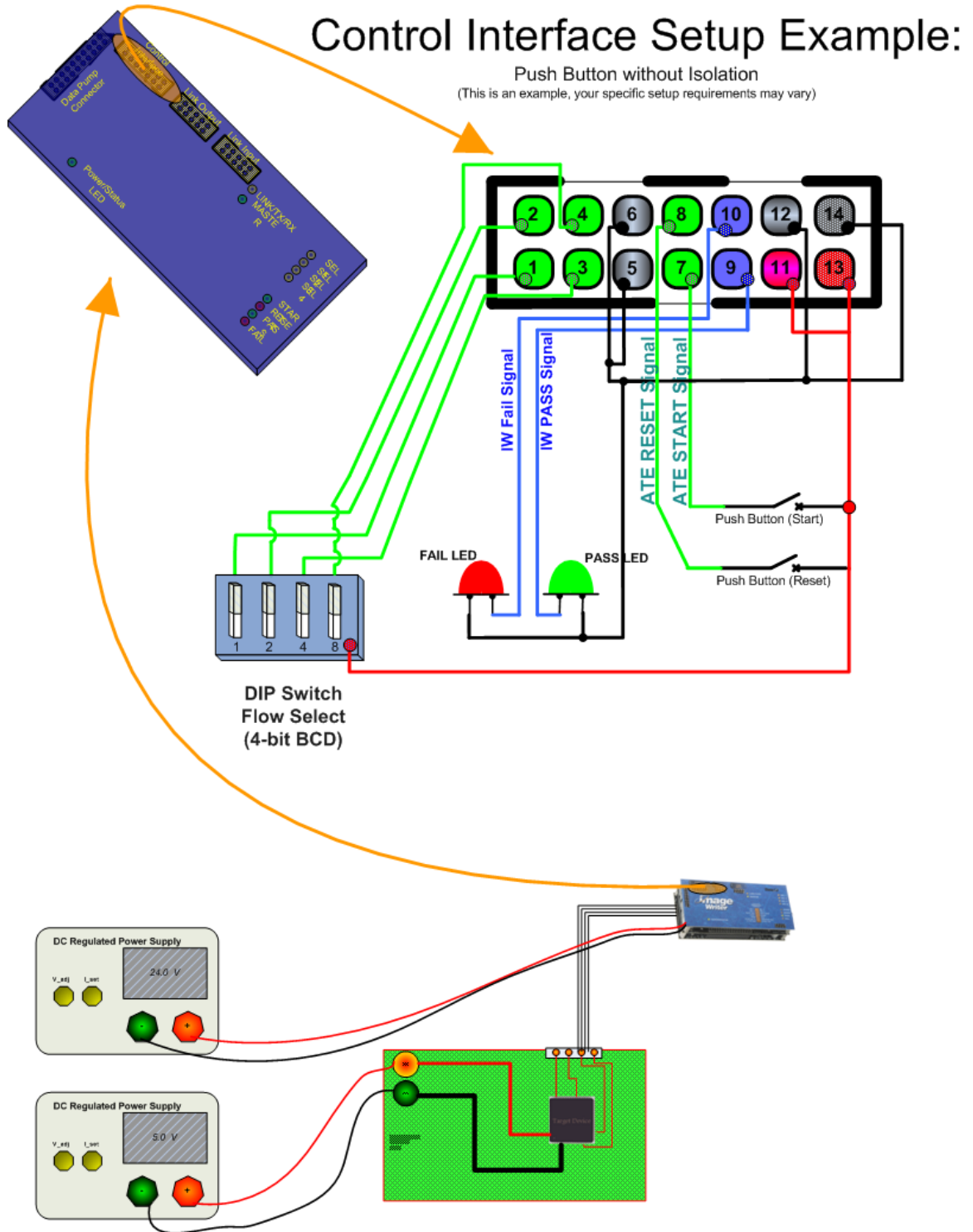

Figure 7-10—Setup Example for Control Interface to Push Buttons

Appendix A: WEEE Symbol

Customer Service Letter



To: **All Hardware Customers** Date: **24-Jul-06**
Subject: **Electrical Equipment Disposal Notice** Document #: **983-0762-001-C**
Product: **All Data I/O Electronic Hardware Products**

Waste of Electrical and Electronic Equipment (WEEE) Symbol



The symbol above (if displayed on your Data I/O product) indicates that the item must not be discarded with general municipal waste. Return products displaying this symbol to Data I/O so that they may be recycled, reused, or otherwise properly disposed of, in accordance with the European Union's WEEE Directive.

Data I/O will, at no cost to the equipment owner, collect this equipment and process it accordingly. Contact Data I/O to receive information about returning marked products with no charge.

In Europe Contact:

Data I/O GmbH
Lochhamer Schlag 5
82166 Gräfelfing, Germany
Telephone: 89-85858-66
Fax: 89-85858-10

In North America Contact:

Data I/O Corporation
6464 185th Avenue NE
Suite 101
Redmond, WA, USA 98052
Telephone: 425-881-6444; 800-426-1045
Fax: 425-869-7423

In China Contact:

Data I/O Electronics (Shanghai) Co. Ltd
Suite A, 25F Majesty Building
138 Pudong Avenue
Shanghai, China PRC 200120
Telephone: 86-21-58827686
Fax: 86-21-58825053

Data I/O Corporation • 6464 185th Avenue NE • Suite 101 • Redmond WA 98052
Fax (425) 869-7423 • e-mail support@dataio.com • USA Tel (800) 426-1045 • Tel +1 (425) 881-6444

Appendix B: EC Declaration of Conformity

EC Declaration of Conformity

We: Data I/O Corporation
6464 185th Avenue N.E., Suite 101
Redmond, WA 98052

declare under sole responsibility that the following described equipment meets the essential health and safety requirements and is in conformity with the EC Directives (listed below) using the relevant section of the following EC standards and other normative documents.

Product designation:	ImageWriter In-System Programmer	
Applicable EC Directives:	Low Voltage Directive 73/23/EEC EC Electromagnetic Compatibility 89/336/EEC	
Applicable Harmonized Standards:	EN 55011	Class A Radiated Emissions
	EN61000-4-2	ESD Immunity
	EN61000-4-3	Radiated Susceptibility
	EN61000-4-4	EFT/Burst Immunity
	EN61000-4-5	Surge
	EN61000-4-6	Conducted Susceptibility
	EN61000-4-8	Magnetic Susceptibility

Applicable National
Technical Standards
And Notified Body: Not Applicable

The CE marking has been affixed on the device according to Article 10 of the EC Directive 98/37/EEC and EC Directive 89/336/EEC.



Carl Olson
Operations Engineering Manager

July, 2006
Date

090-0744-001b

Appendix C: ImageWriter Mounting Dimensions and Template

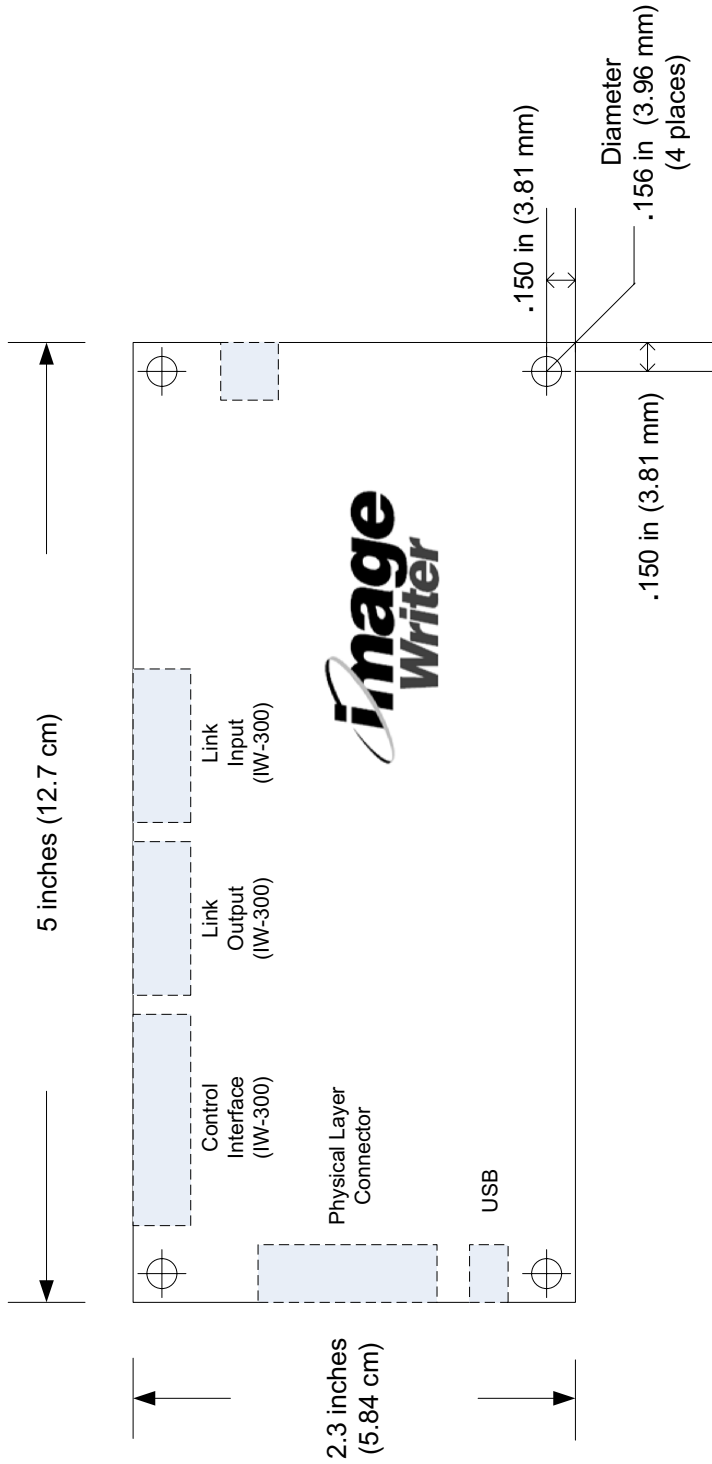

Scale	1:1
Recommended clearance:	5.5 inches by 2.8 inches
Screws (4)	# 4-40

List of Tables

1 — Introduction

ImageWriter Specifications	1-9
Contact Information	1-13

2 — Setup

Connection Options Chart	2-3
------------------------------------	-----

3 — Computer Interface Language (CIL) for IW-200

CIL Responses	3-1
IW-200 Memory Commands	3-4
IW-200 Object Commands	3-7
IW-200 System Commands	3-8
IW-200 Terminal Commands	3-9

4 — Computer Interface Language (CIL) for IW-300

CIL Responses	4-2
IW-300 Memory Commands	4-4
IW-300 Object Commands	4-7
IW-300 System Commands	4-8
IW-300 Terminal Commands	4-9
IW-300 Flow Commands	4-10
IW-300 Network Commands	4-12

5 — IW-200 Errors

IW-200 Numeric Error Codes	5-3
IW-200 Data Pump Layer High Priority Error Blink Pattern	5-3

6 — IW-300 Errors

IW-300 Numeric Error Codes	6-4
IW-300 Data Pump Layer High Priority Error Blink Pattern	6-5
IW-300 Control Layer High Priority Error Blink Pattern	6-5

7 — ImageWriter Reference

Data Pump Features	7-1
Physical Layer Features	7-2
Physical Layer Connector Pin Descriptions	7-3
Control Layer Features	7-4

List of Figures

1 — Introduction

ImageWriter-200 (Left); ImageWriter-300 (Right)	1-1
Link Networked IW-300s	1-2
USB Networked IW-300s	1-3
Interconnected IW-300s	1-3
IW-300 Showing Three Layers of Hardware	1-4
Physical Layer	1-4
Data Pump Layer	1-5
Control Layer	1-5
ImageWriter Tools	1-6
Open IW Tools Help	1-7
ImageWriter Tools Help	1-7
Package Contents	1-10
Warning Symbols Used in This Guide	1-11
“Do Not Dispose” Label	1-11

2 — Setup

Plug the USB Cable into IW	2-4
Plug AC Adapter into Auxiliary Power Connector.	2-4
Found New Hardware	2-5
Found New Hardware Wizard	2-5
After “Command completed successfully”, click SEND A DEVICE LIBRARY.	2-6
Select Device Library and Click SEND	2-7
Sample SETUP CHART in Device Support Detail & Setup Document	2-8
Control Interface Connector Pin Chart	2-10
Push Button Without Isolation	2-11
IW-300 to ATE	2-12
Four Interconnected IW-300s	2-13
Interconnected IW-300s Power and Device Connections	2-14
Link Networked ImageWriter-300s: One Master IW-300 and up to 31 Linked IW-300s.	2-15
Plug the USB Cable into Master IW-300	2-16
Enter a Name, Select an Icon, and Click OK	2-17
ImageWriter Will Usually Be the Highest Number COM Port.	2-18
Factory Default Communications Settings For IW	2-18

3 — Computer Interface Language (CIL) for IW-200

CIL Command Example	3-1
Sample Object Chart	3-5
CIL Example	3-10

4 — Computer Interface Language (CIL) for IW-300

CIL Command Syntax Example	4-1
Sample Object Chart	4-5
IW-300 Flow Example	4-11
Power/Status LED	4-13
CIL Response to NPNG Command	4-13
Responses to NPNG Command	4-14
Command Effect on Network Selection	4-14
Default Network Status (No IW-300s Selected)	4-15
NSEL 0	4-15
NSEL 6	4-16
NALL	4-16
No Address	4-17
NPNG 3	4-17
Deselected Units Busy Running Flow	4-18

7 — ImageWriter Reference

Data Pump	7-1
Physical Layer	7-2
Physical Layer Connector	7-3
Control Layer	7-4
Control Interface Connector	7-5
Control Interface Pin Descriptions	7-5
Setup Example for SPI Protocol	7-8
Setup Example for Microchip Serial Protocol	7-9
Setup Example for Control Interface to ATE	7-10
Setup Example for Control Interface to Push Buttons	7-11

Index

A

- Address change 1-12
- Algorithm, see also *Device library*
- ATE setup example 7-10
- Auxiliary Power Connector, power when configuring 2-1

C

- Cancel operation (IW-200) 3-2
- Cancel operation (IW-300) 4-2
- CIL (IW-200)
 - command syntax 3-1
 - example flowchart 3-10
 - responses, pass and fail 3-1
- CIL (IW-300)
 - command syntax 4-1
 - responses, pass and fail 4-1
- Command syntax
 - CIL (IW-200) 3-1
 - CIL (IW-300) 4-1
- Communication settings, factory default 2-18
- Compliance, EC 1-9
- Computer Interface Language, see also *CIL*
- Connection options chart 2-3
- Connections for configuring IW without target board 2-4 to 2-7
- Connections for link networking IW-300s 2-15 to 2-16
- Connections for programming with IW 2-8 to 2-11
- Control Interface
 - connector features 7-5
- Control Layer (IW-300)
 - description 1-5
 - features 7-4
 - high priority errors 6-5

D

- Data file
 - configurations for downloading to IW 2-4
 - IW Tools help 2-7
- Data I/O contact information 1-13

- Data Pump (IW-200) high priority errors 5-3
- Data Pump (IW-300) high priority errors 6-5
- Data Pump Layer
 - description 1-5
 - features 7-1
- DC input power 1-9
- Declaration of conformity, EC B-1
- Device library, downloading 2-4
- Dimensions C-1
- Disposal directions 1-11

E

- EC compliance 1-9
- EC, declaration of conformity B-1
- Electrostatic Discharge, see also *ESD*
- Errors (IW-200)
 - high priority errors defined 5-1
 - high priority errors table 5-3
 - standard errors defined 5-1
 - standard errors table 5-1 to 5-3
- Errors (IW-300)
 - Control Layer high priority errors 6-5
 - high priority errors defined 6-1
 - high priority errors table 6-5
 - standard errors defined 6-1
 - standard errors table 6-1 to 6-4
- Esc key
 - cancel operation (IW-200) 3-2
 - cancel operation (IW-300) 4-2
- ESD 1-11

F

- Features
 - IW-200 1-1
 - IW-300 1-2
- Firmware update (IW Tools) 1-6
- Flow (IW-300)
 - commands 4-10
 - example 4-11
 - table of Flow commands 4-10
- Flow Editor (IW Tools) 1-6

H

- Hardware components 1-4
- Hardware set up 2-16
- Humidity range, operating 1-9
- HyperTerminal, checking communication 2-17

I

- ImageWriter (IW) Tools
 - description 1-6
- Interconnected network 1-3
- IW-300, start up 7-7

K

- Knowledge Base 1-14

L

- Language, see also *CIL*
- LEDs
 - on Control Layer 1-6, 7-4
 - on Data Pump Layer 1-5, 7-1
 - on Physical Layer 1-4, 7-2
- Link network 1-2
- Link network setup 2-15 to 2-16
- LINK/TX/RX (LED) 1-6, 7-4

M

- Measurements 1-9
- Memory Card
 - features 7-1
 - not usable in computer 1-5
 - replacement information 7-1
- Memory commands (IW-200) 3-3
- Memory commands (IW-300) 4-3
- Memory types
 - static and dynamic (IW-200) 3-3
 - static and dynamic (IW-300) 4-3
- Microchip serial interface
 - setup example 7-9
- Mounting dimensions C-1

N

- Network commands (IW-300) 4-12
- Network interface, description 7-6
- Network ping, see also *Ping*

Network types

- Interconnected 1-3
- Link 1-2
- USB 1-3

O

- Object commands (IW-200) 3-5
- Object commands (IW-300) 4-5
- Operating System, Windows 2000 / XP 1-9

P

- Physical Layer
 - description 1-4
 - features 7-2
- Physical Layer connector
 - pin names and descriptions 7-3
- Physical measurements 1-9
- Pin driver output 1-9
- Ping 4-13
- Pins 19 and 20, power in test fixture 2-1
- Power supply options 2-1
- Programmer Control Panel (IW Tools) 1-6
- Programming with IW (setup) 2-8 to 2-11
- Protocols
 - SPI, I2C, RS-232, JTAG 1-1
- Push button setup example 7-11

R

- Returning IW 1-11

S

- Safety 1-10
- Script, see also *Flow*
- Self-test 2-2
- Setup control interface to ATE 7-10
- Setup control interface to push buttons 7-11
- Setup for Serial protocol 7-9
- Setup for SPI interface 7-8
- Setup options chart 2-3
- Specifications 1-9
- SPI interface, setup example 7-8
- Start up (IW-300) 7-7
- Syntax
 - CIL commands (IW-200) 3-1
 - CIL commands (IW-300) 4-1
- System commands (IW-200) 3-8
- System commands (IW-300) 4-8

T

- Temperature range, operating 1-9
- Template C-1
- Terminal mode commands (IW-200) 3-9
- Terminal mode commands (IW-300) 4-9

U

- Update firmware (IW Tools) 1-6
- USB interface 1-7
- USB network 1-3
- USB required computer facility 1-9

W

- Warranty 1-11
- WEEE symbol A-1
- Windows 2000 / XP 1-9



Data I/O Corporation:

6464 185th Avenue NE, Suite 101, Redmond WA 98052, USA ·
(425) 881-6444 · (800) 332-8246 · <http://www.dataio.com>

Data I/O GmbH:

Lochamer Schlag 5, 82166 Graefelfing, Germany · 089 858580 · <http://www.dataio.de>

Data I/O China:

Suite A, 25F Majesty Building, 138 Pudong Avenue, Shanghai, 200120, China PRC ·
86-21-58827686 · <http://www.dataio.cn>